

REDBIRD FLIGHT SIMULATIONS

LD, SD, FMX and MCX
QUALIFICATION AND APPROVAL GUIDE (QAG)



ADVANCED AVIATION TRAINING DEVICE

William Jen

Redbird Flight Simulations, Inc.
301 Vista Ridge DR., Suite 300
Kyle, Texas 78640

<http://www.redbirdflight.com>
info@redbirdflight.com

(512) 301-0718 Phone / (512) 301-0770 Fax

October 22, 2025

VERSION 4.12A

Table of Contents

LOG OF REVISIONS.....	ii
LIST OF EFFECTIVE PAGES	v
SECTION 1: COMPLIANCE STATEMENT.....	1
SECTION 2: AVIATION TRAINING DEVICE (ATD) DESCRIPTION AND PICTURES	2
Redbird LD.....	3
Redbird SD.....	4
Redbird FMX.....	5
Redbird MCX	6
Configuration Components	9
Instructor’s Station	9
Redbird GIFT – PPL/IR	11
RBPro	13
CONNECT	15
Corvus	15
Cygnus Home/Cygnus Pro.....	15
Aircraft Instrument Configurations.....	16
Modular Controls.....	19
SECTION 3: TRAINING DEVICE COMPONENTS LIST	23
SECTION 4: AVIATION TRAINING DEVICE (ATD) DESIGN CRITERIA LIST	26
Basic ATD Requirements List [Appendix B items]	26
Advanced ATD Requirements List [Appendix C items].....	30
SECTION 5: AIRCRAFT CONFIGURATIONS.....	31
List of Previously Approved Configurations:	31
Performance Table	97
SECTION 6: VISUAL SYSTEM WITH IFR, VFR, DAY, AND NIGHT CAPABILITY	100
SECTION 7: ATD FUNCTIONS & MANEUVERS CHECKLISTS	104

LOG OF REVISIONS

Description of Changes	Version	Edited By
Added image 7 & 8	4.5E	WJ
Updated image 5.2	4.5E	WJ
Updated GLS approach to "No" in Section 7	4.5E	WJ
Updated for AC-136B Compliance	4.6	WJ
Added reference to Figures 5.8 and 5.9 for optional equipment	4.6	WJ
Added 27" (6) and (8) monitor options to Component List	4.6	WJ
Moved configurations added in 4.5E to Previously Approved	4.6	WJ
Updated description to include dimensions for larger monitors.	4.6	WJ
Added Figures 5.8 and 5.9	4.6	WJ
Updated text in Compliance Statement	4.6A	WJ
Listed SD and MCX/SD as individual models	4.6A	WJ
Enlarged image for Figure 5.2	4.6A	WJ
Added avionics manufacturer information in Component List	4.6A	WJ
Updated text for C3.1.9	4.6A	WJ
Updated Procedures and Tasks Test Checklist	4.6A	WJ
Added description for MCX/LD	4.6B	WJ
Added PA34T configurations	4.6C	WJ
Updated Figure descriptions to include monitor size	4.6D	WJ
Corrected typo in Section 7 on item 5)	4.6E	WJ
Separated Software (Table 1) and Hardware (Table 2) on Component List	4.7	WJ
Separated Performance Table. "Single" (Table 3) and "Multi" (Table 4)	4.7	WJ
Added optional Dual Starter Retrofit kit for LD, SD, FMX	4.7	WJ
Added Switchpanel 3	4.7	WJ
Moved PA34T-S and PA34T-G to Previously Approved Configurations	4.7	WJ
Relabeled "Figures" as "Images" for consistency	4.7	WJ
Relabeled Figure in Section 6 as Diagram 1	4.7	WJ
Added C172RG & C182RG Configurations	4.7	WJ
Added Piper PA28-60-G2 Configuration	4.7	WJ
Added Tecnam P2010 Configuration	4.7	WJ
Updated TOC to reflect added aircraft configurations in v4.7	4.7A	WJ
Added TRACON and Corvus to Table 1	4.7A	WJ
Added second page to Log of Revisions	4.7B	WJ
Added GIFT to Table 1	4.7B	WJ
Added Type-5 Multi-Engine Throttle Quadrant - Image 23(a)	4.7C	WJ
Added PA38 Piper Tomahawk Aircraft Configuration	4.7C	WJ
Corrected AP for P2010 from STEC to GFC700	4.7D	WJ
Updated Compliance Statement according to new FAA template	4.7E	WJ
Provided additional clarity on devices in Section 2 per AFS-800	4.7E	WJ
Updated/added additional IOS images per request from AFS-800	4.7E	WJ
Deleted Statements of Compatibility of Software and Hardware per request from AFS-800	4.7E	WJ
Updated Section 4 - BATD/AATD Requirements to statements in the Affirmative according to new FAA template	4.7E	WJ
Removed individual aircraft configurations from ToC per request from AFS- 800	4.7E	WJ
Removed W&B Information from A/C Configuration per request from AFS-800	4.7E	WJ
Updated Performance Tables with V_G according to new FAA template	4.7E	WJ
Updated Section 7 according to new FAA template	4.7E	WJ
Updated entry for simulating engine failure	4.7F	WJ
Removed reference to MCX/SD in Section 4	4.7F	WJ
Corrected configuration typo – Throttle corrected to (T-M)	4.7G	WJ

Updated Cover page according to FAA template	4.7H	WJ
Added aircraft configurations to Section 2 according to FAA template	4.7H	WJ
Updated reference to AC61-136B with AC61-136 per FAA request	4.7H	WJ
Corrected typo in B.3.3.2	4.7H	WJ
Updated Section 7 with the correct text from FAA template	4.7H	WJ
Removed Affected Pages from Log of Revisions	4.7I	WJ
Updated Engine Failure to oil pressure loss in Section 7	4.7I	WJ
Included verbiage from updated (12/15/19) FAA Template	4.7I	WJ
Added List of Effective Pages	4.8	WJ
Added Maul MX7-180B	4.8	WJ
Updated images 16, 17, 18, 19	4.8	WJ
Added Carb Heat Controls (image 46)	4.8	WJ
Moved configurations added in 4.7I to Previously Approved Configurations	4.8	WJ
Updated Log of Revisions and List of Effective Page for Pages 22-79, 82	4.8A	WJ
Added Maul 5k Performance information	4.8A	WJ
Updated Footer Revision number	4.8A	WJ
Reformatted Log of Revision	4.9	WJ
Reformatted List of Effective Pages	4.9	WJ
Added DA20-C1 to Section 2	4.9	WJ
Added description for CONNECT, GIFT, CORVUS, Cygnus Pro – Section 2	4.9	WJ
Added RBPro and CONNECT – Section 3	4.9	WJ
Added PilotEdge – Section 3	4.9	WJ
Removed Parrot – Section 3	4.9	WJ
Removed Tracon – Section 3	4.9	WJ
Moved configurations added in 4.8 to Previously Approved Configurations	4.9	WJ
Added additional panel configurations for DA42 to Section 5	4.9	WJ
Corrected Autopilot Information for Aircraft Configuration	4.9A	WJ
Replaced images 10 & 11	4.9A	WJ
Removed images 50 & 51	4.9A	WJ
Moved DA42 configurations added in v4.9 to Previously approved Configurations	4.10	WJ
Adding C172RG-S2 (Analog w/KLN94 GPS)	4.10	WJ
Added C182RG-S2 (Analog w/KLN94 GPS)	4.10	WJ
Added BE55-G1 (G1000 w/GFC700) configuration and throttle	4.10	WJ
Corrected VS0 and VS1 airspeeds for C172RG and C206	4.10	WJ
Revised image/diagram numbers and references	4.10	WJ
Added AOA Gauge to Aircraft Instrument Configurations	4.11	MH
Added AOA Gauge to Training Device Component List	4.11	MH
Moved configurations added in 4.10 to Previously Approved Configurations	4.11	MH
Removed Piper Warrior with G1000	4.12	WJ
Added Piper Archer G1000 with Aspen Backup	4.12	WJ
Updated information for AoA Gauge	4.12	WJ
Removed Liberty LXL2	4.12A	WJ
Corrected image & auto-pilot description for DA42-G2 configuration	4.12A	WJ
Removed duplicate DA42L entry listed as DA42L-G1	4.12A	WJ
Updated List of Effective Pages	4.12A	WJ

This page intentionally left blank.

LIST OF EFFECTIVE PAGES

The List of Effective Pages (LOEP) lists all the basic pages, with effective approval dates, of the Qualification and Approval Guide. Pages affected by the current revision are indicated by an asterisk (*) following the revision code.

Version 4, Rev 5E	June 6 2018
Version 4, Rev 6E	February 15 2019
Version 4, Rev 7I	January 14 2020
Version 4, Rev 8A	August 20 2020
Version 4, Rev 9A	October 8 2021
Version 4, Rev 10	November 13, 2023
Version 4, Rev11	July 12, 2024
Version 4, Rev 12A(*)	October 22, 2025

Section	Pages	Revision
	Pages i, ii	Rev 10
	Pages iii, v	Rev 12A(*)
	Pages iv	Rev 8A
Section 1	Pages 1	Rev 7H
Section 2	Pages 2	Rev 12A(*)
	Pages 3-17	Rev 10
	Pages 18	Rev 12A(*)
	Pages 19-22	Rev 10
Section 3	Pages 23	Rev 11
	Pages 24,25	Rev 7E
Section 4	Pages 26,30	Rev 7H
	Pages 27,29	Rev 7F
	Pages 28	Rev 7I
Section 5	Pages 31-66	Rev 10
	Pages 67-68	Rev 12A(*)
	Pages 69-77	Rev 10
	Pages 78	Rev 12A(*)
	Pages 79 - 93	Rev 10
	Pages 94-96	Rev 12A(*)
	Pages 97	Rev 10
	Pages 98	Rev 12A(*)
	Pages 99	Rev 4.7E
Section 6	Pages 100	Rev 6
	Pages 101-103	Rev 10
Section 7	Pages 104	Rev 7E
	Pages 105	Rev 7I
	Pages 106	Rev 7H

**FAA APPROVED QAG
Signature and Date**

**for Daniel Kelman, Acting Manager
Training and Simulation Group**

SECTION 1: COMPLIANCE STATEMENT

This Qualification and Approval Guide (QAG) provides a detailed description of all the required components, features, functions, and capabilities for the Redbird Flight Simulations, Inc. models LD, SD, FMX, MCX aviation training device. This includes any optional airplane configurations with quality color pictures and diagrams. This QAG is provided by Redbird Flight Simulations, Inc. to clearly describe and verify the required functionality of this aviation training device platform confirming its suitability for airman training and experience. The information as described in advisory circular AC 61-136, FAA Approval of Aviation Training Devices (ATD) and Their Use for Training and Experience is provided within this document. This includes listing all of the required qualifying items, functions, and capabilities. A valid FAA Letter of Authorization (LOA) specifying the credit allowances must accompany the training device when utilized for satisfying airman training or experience requirements specified in 14 CFR §61 or 141. Additionally, FAA Order 8900.1 Volume 11 Chapter 10 Section 1 provides guidance to aviation safety inspectors facilitating ATD evaluations, approvals and oversight.

Redbird Flight Simulations, Inc. will provide a detailed Operations Manual with each aviation training device model produced. This will include how to properly start, operate, and shut down the trainer. This must include how to operate and maintain the trainer as originally designed and tested. Redbird Flight Simulations, Inc. will ensure that the operator of this training device is familiar and proficient with all the features and capabilities of this trainer, and how to correct any malfunctions that may occur.

The operator of this aviation training device is expected to become proficient in its operation before using it to satisfy any pilot experience requirements specified in the code of federal regulations. This includes maintaining its condition and functionality. This ATD must be maintained to its original performance and functionality, as demonstrated during the original FAA functional evaluation. This trainer cannot be used to log pilot time unless all the components of the trainer are in normal working order.

Only the airplane configurations approved for this model can be utilized when satisfying FAA experience or training requirements. Any additions, changes, or modifications to this model, or the associated configurations, must be evaluated and approved in writing by the General Aviation and Commercial Division. This does not prohibit software updates that do not otherwise change the appearance of the systems operation. Operators who use these trainers to satisfy FAA pilot training or experience requirements specified in part 61 or 141 are obligated to allow FAA inspection ensuring acceptable function and compliance.

Any questions concerning FAA approval or use of ATDs should be directed to the General Aviation and Commercial Division.

SECTION 2: AVIATION TRAINING DEVICE (ATD) DESCRIPTION AND PICTURES

The Redbird LD, SD, FMX, and MCX models are based on the dimensions and layout of a several production Single and Multi-Engine Land aircrafts. These models closely represent the overall functionality, performance, avionics, and instrumentation. The platform consists of a cockpit section, instructor's control station, visual display system and an audio system. It incorporates a combination of hardware and software components that is assembled and checked by Redbird Flight Simulations. All hardware elements are permanently installed and designed so the cockpit has the appearance and feel of an actual aircraft. From the pilot's seated position, there are no computer hardware elements such as keyboards, pointing devices, etc. for his or her use.

The Redbird LD, SD, FMX, and MCX models provide a realistic flight deck design, avionics interface, and reliable hardware/software performance. This platform provides an effective training environment for students and pilots in training. This includes the ability to accomplish scenario based flight training activities, instrument procedures and experience, pilot proficiency evaluations, simulated equipment failure, emergency procedures, and facilitates increased pilot competency.

Airplane Single Engine Land representing:

Beechcraft (A36) Bonanza	Cessna 206 Stationair TC	Maul MX7-180B	Socata TB10
Cessna 172 Skyhawk	Cirrus SR20	Mooney M20TN (Type S)	Tecnam P2010
Cessna 172RG Cutlass RG	Cirrus SR22	Piper PA-28-161 Warrior III	
Cessna 182 Skylane	Diamond DA20	Piper PA-28-181 Archer III	
Cessna 182RG Skylane RG	Diamond DA20-C1	Piper PA-28R-201 Arrow	
Cessna 206 Stationair	Diamond DA40	Piper PA-38-112 Tomahawk	

Multi-Engine Land representing:

Beechcraft (BE55) Baron	Diamond DA42 L360	Piper PA-34T Seneca	Tecnam P2006
Beechcraft (BE58) Baron	Diamond DA42 NG	Piper PA-44 Seminole	
Beechcraft (BE76) Duchess	Piper PA-34 Seneca	Piper PA-44T Seminole	

The Redbird family of simulators is versatile, expandable and affordable devices that have been designed to be representative of popular single and twin-engine piston aircraft. They offer the user the ability to change the cockpit controls and aircraft models to represent a wide range of popular training aircraft.

Redbird LD



Image 1: Redbird LD

- Single pilot control with optional 2-axis control-loaded yoke and pilot rudder pedals. See Image 27, 28, 29, 64 (Optional pilot seating platform required for center-stick yoke)
- Open flight deck with wrap-around exterior visuals provided by 6 LCD screens. See Image 65, 66, 67, 68.
- Realistic switches, buttons, knobs, circuit breakers and other cockpit controls that are designed to represent the family of aircraft. See Image 44-48, 52-62.
- An interchangeable instrument panel, throttles, and yokes to allow a quick-change configuration options to the end user. See Image 25-41.
- Closed Circuit intercom system, allowing for communication between the pilot, co-pilot and instructors using standard aviation headsets. See Image 52, 53.
- A portable instructor's station, allowing the instructor to operate from inside or outside the simulator. See Images 14-16.

Redbird SD



Image 2: Redbird Cockpit Enclosure



Image 3: Redbird FMX and SD Instrument Panel

- Single pilot control with optional 2-axis control-loaded yoke and pilot rudder pedals. See Image 27, 28, 29, 64.
- Enclosed cockpit with pilot and copilot seating. See Images 3, 12, 13.
- Wrap-around exterior visuals provided by 6 or 8 LCD screens. Image 65, 66, 67, 68.
- Realistic switches, buttons, knobs, circuit breakers and other cockpit controls that are designed to represent the family of aircraft. See Image 44-48, 52-62.
- An interchangeable instrument panel, throttles, and yokes to allow a quick-change configuration options to the end user. See Image 25-41.
- Closed Circuit intercom system, allowing for communication between the pilot, co-pilot and instructors using standard aviation headsets. See Image 52, 53.
- A portable instructor's station, allowing the instructor to operate from inside or outside the simulator. See Images 14-16.

Redbird FMX



Image 4: Redbird FMX/MCX Exterior & Motion Platform



Image 3: Redbird FMX and SD Instrument Panel

- Single pilot control with optional 2-axis control-loaded yoke and pilot rudder pedals. See Image 27, 28, 29, 64.
- Enclosed cockpit with pilot and copilot seating. See Images 3, 12, 13.
- 3-axis electric motion platform providing pitch, roll and yaw motions. See Images 4, 6, 10-11.
- Wrap-around exterior visuals provided by 6 or 8 LCD screens. Image 65, 66, 67, 68.
- Realistic switches, buttons, knobs, circuit breakers and other cockpit controls that are designed to represent the family of aircraft. See Image 44-48, 52-62.
- An interchangeable instrument panel, throttles, and yokes to allow a quick-change configuration options to the end user. See Image 25-41.
- Closed Circuit intercom system, allowing for communication between the pilot, co-pilot and instructors using standard aviation headsets. See Image 52, 53.
- A portable instructor's station, allowing the instructor to operate from inside or outside the simulator. See Images 14-16.

Redbird MCX



Image 6: Redbird FMX/MCX Exterior & Motion Platform



Image 7: Redbird MCX Instrument Panel

- Dual pilot controls with optional 2-axis control-loaded yoke and interconnected rudder pedals. See Image 30, 44
- Enclosed cockpit with pilot and copilot seating. See Images 3, 12, 13.
- 3-axis electric motion platform providing pitch, roll and yaw motions. See Images 4, 6, 10-11.
- Wrap-around exterior visuals provided by 6 or 8 LCD screens. Image 65, 66, 67, 68.
- Realistic switches, buttons, knobs, circuit breakers and other cockpit controls that are designed to represent the family of aircraft. See Image 44-48, 52-62.
- An interchangeable instrument panel and throttles to allow a quick-change configuration options to the end user. See Image 25-41.
- Closed Circuit intercom system, allowing for communication between the pilot, co-pilot and instructors using standard aviation headsets. See Image 52, 53.
- A portable instructor's station, allowing the instructor to operate from inside or outside the simulator. Images 14-16.

**The Redbird MCX is optionally configurable in a non-motion enclosed cockpit configuration referred to as the "MCX-SD" and an open flight deck configuration referred to as the "MCX-LD".*



Image 1: Redbird LD



Image 2: Redbird Cockpit Enclosure



Image 8: Redbird FMX and SD Instrument Panel



Image 9: Redbird MCX Instrument Panel

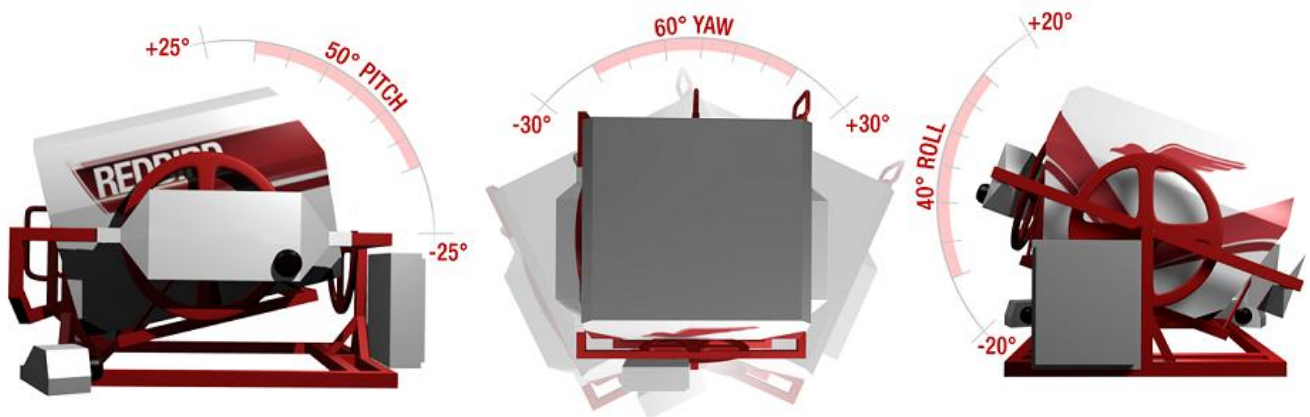

Image 10: Redbird Motion Platform



Image 11: Redbird FMX/MCX Exterior & Motion Platform



Image 12: Redbird FMX Seats (w/ center stick yoke mount)



Image 13: Redbird MCX Pilot & Co-pilot Seats

Configuration Components

Instructor's Station

The Redbird Instructor Station interface is operated through any PC or browser enabled device.

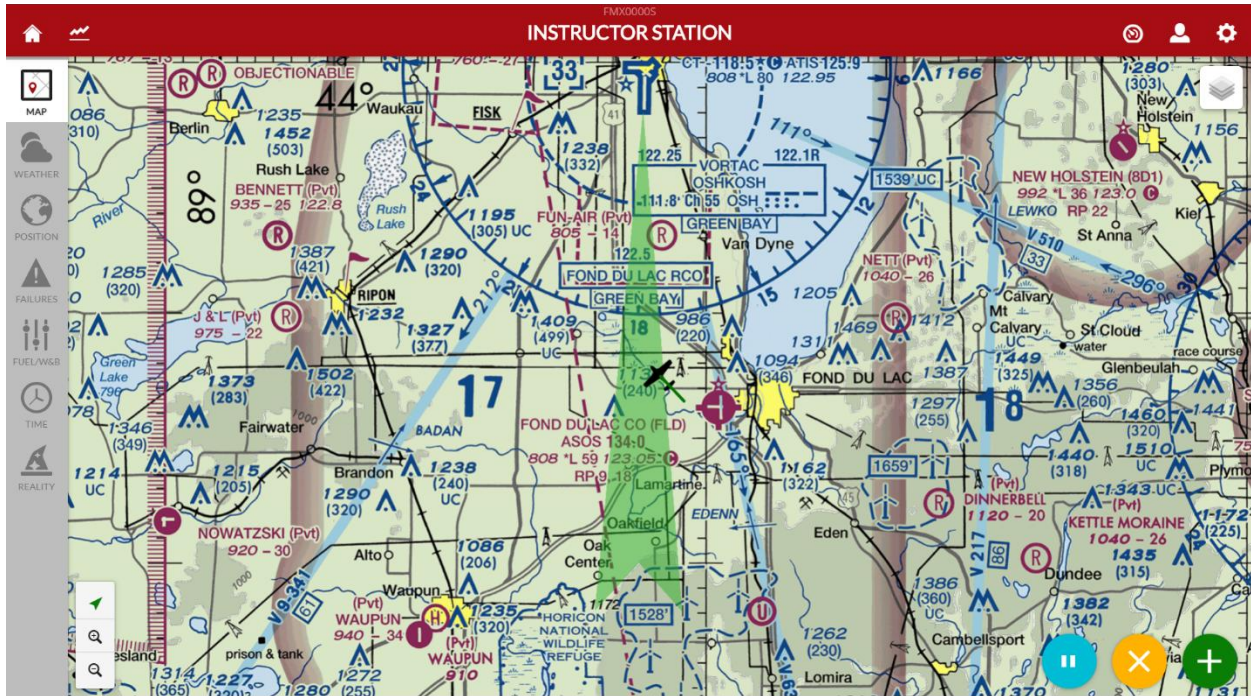

Image 14: Redbird's Instructor's interface Map Tab

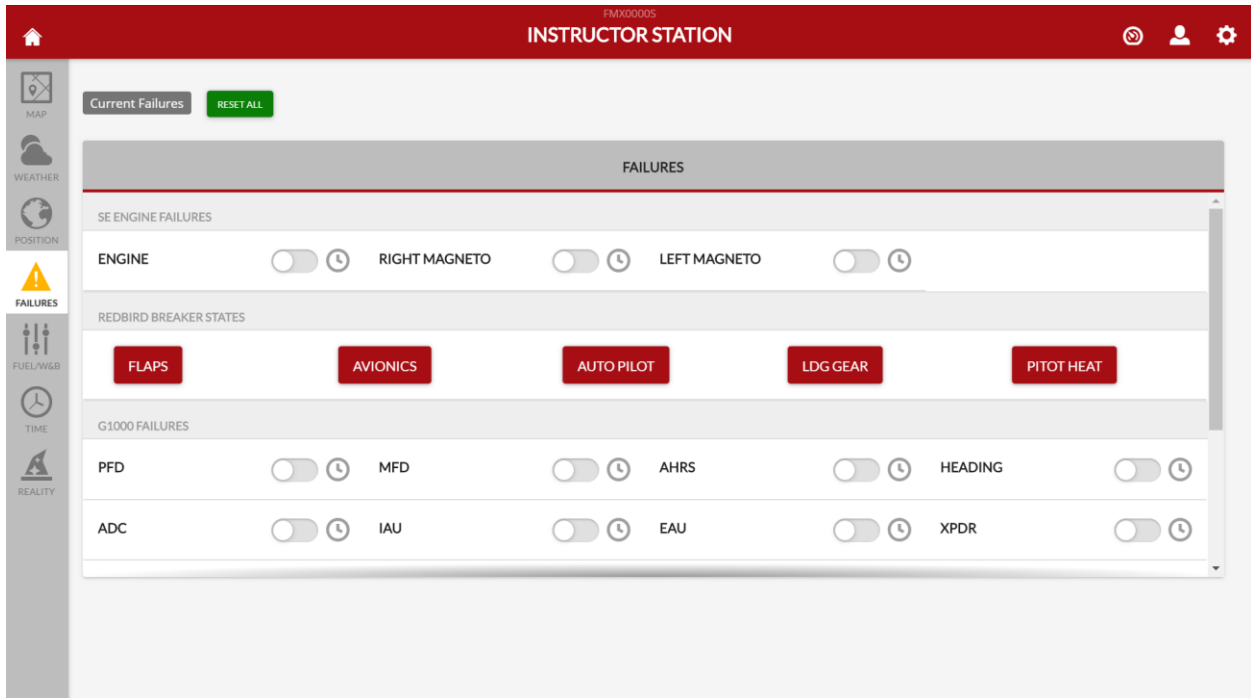



Image 15: Redbird's Instructor's interface Failure Tab

FMX0005
INSTRUCTOR STATION
🏠 👤 ⚙️

MAP

METAR
 0000KT 1 1/2SM OVC006 15/05 A2991

WEATHER

BASIC WEATHER

ADVANCED WEATHER

SURFACE CONDITIONS: EDIT ALL

<input type="button" value="EDIT"/>	Temp & Pressure:	15/05 29.91
<input type="button" value="EDIT"/>	Surface Visibility:	1 1/2SM 010MSL
<input type="button" value="EDIT"/>	Surface Wind:	0000KT 010MSL Turbulence: None Wind Shear: Gradual

VISIBILITY: ADD LAYER CLEAR ALL

<input type="button" value="EDIT"/>	Surface Visibility:	1 1/2SM 010MSL
<input type="button" value="EDIT"/>	Visibility Layer 1:	1/4SM 011 TO 161MSL

CANCEL

Image 16: Redbird's Instructor's interface Weather Tab

Redbird GIFT – PPL/IR

Redbird Guided Independent Flight Training (GIFT) is a simulator-based maneuvers training supplement that allows the student to learn, practice, and receive feedback on maneuvers required for Private Pilot or Instrument Rating.

GIFT includes:

- A video and written pre-flight briefing
- A simulator mission with an AI-powered instruction that provides real-time coaching and corrections based on the pilot's performance.
- A post-flight debrief with objective scoring based on the FAA Airmen Certification Standards
- In-depth post-flight review and trend tracking by uploading completed lesson history to the Redbird Cloud

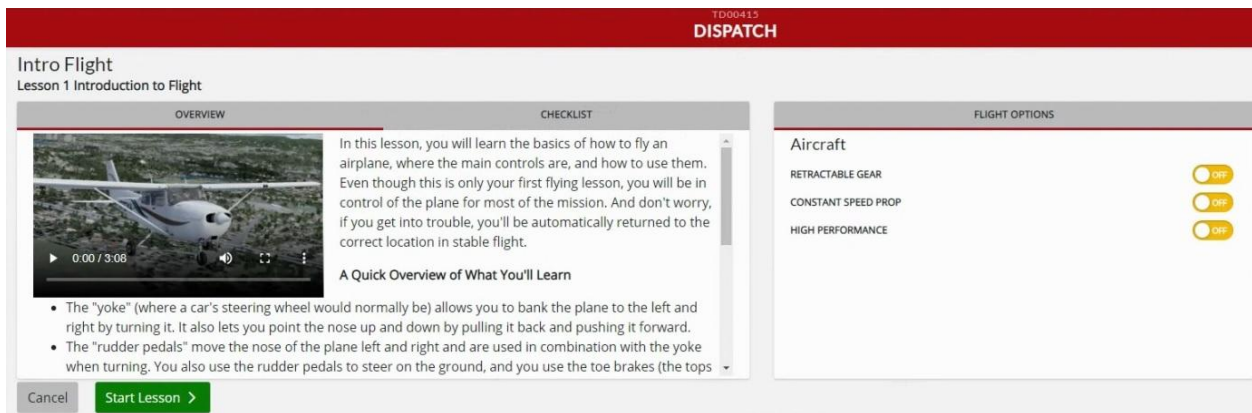

Image 17: GIFT Dispatch Screen



Image 18: GIFT Instructional Virtual Gate

P3DV4VIDEO
SCORE

Meets ACS





DESCRIPTION	PERFORMANCE	TARGET	AVERAGE	DEVIATION	
Prior to Entry	<i>Meets ACS</i>				
Assigned Heading	 90.4%	320	322	307	322
Approach Path	<i>Meets ACS</i>				
KIAS	 89.9%	90	92	91	94
CDI Deflection	 96.5%	Centered	1/8 left	1/8 right	1/8 left
GSI Deflection	 94.0%	Centered	1/8 above	1/8 below	2/8 above
Tuned to Approach	<i>Meets ACS</i>				
Tuned to ILS	<i>Meets ACS</i>				
Tuned to Tower	<i>Meets ACS</i>				
Land Runway 36	<i>Meets ACS</i>				
Overall Score	 92%				
CLOSE					

Image19: GIFT Sample Scoring Analysis

RBPro

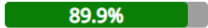
RBPro Training is a simulator-based training supplement that allows the pilot to practice and receive feedback on maneuvers to maintain pilot proficiency.

RBPro includes:

- A video and written Pre & Post flight briefings with objective scoring
- Proficiency scenarios and quizzes designed by FAA licensed CFI/II from across the US
- In-depth proficiency trend and progression tracking

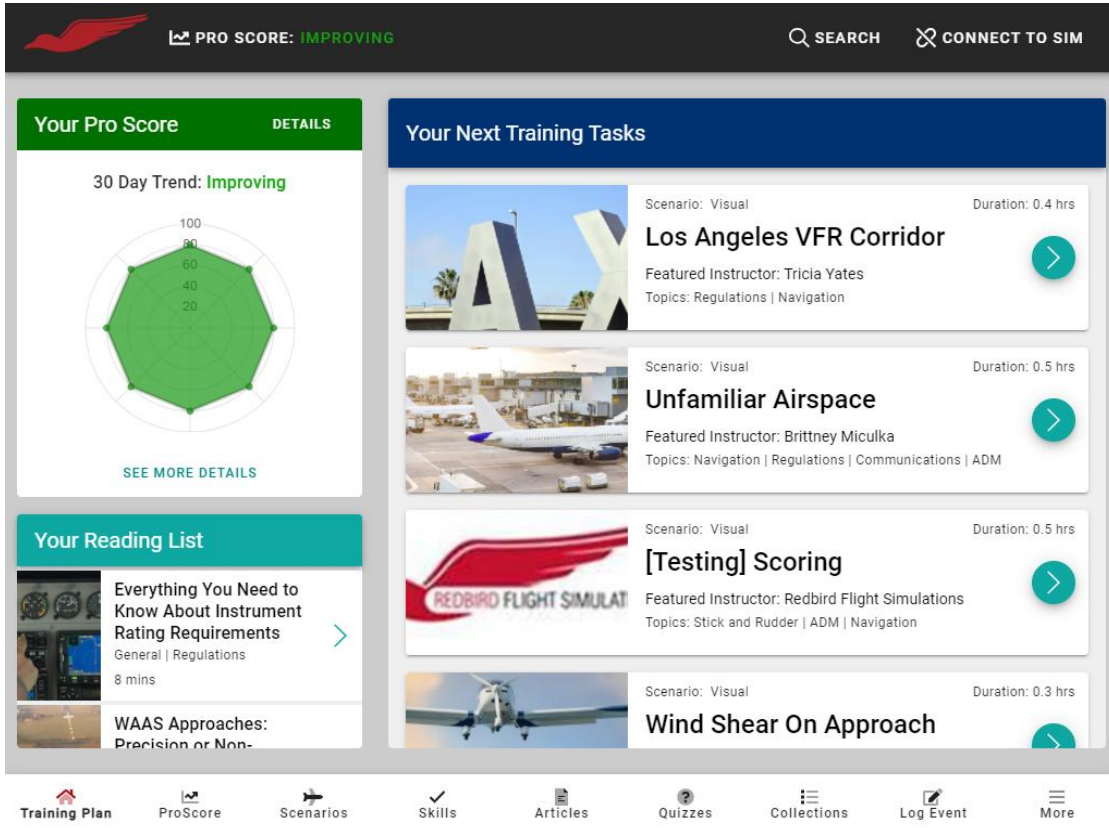

The screenshot displays the RBPro Main Page interface. At the top, there is a dark header with the Redbird logo on the left, a 'PRO SCORE: IMPROVING' indicator in the center, and 'SEARCH' and 'CONNECT TO SIM' buttons on the right. The main content area is divided into three columns. The left column, titled 'Your Pro Score', shows a '30 Day Trend: Improving' and a radar chart with a score of approximately 85. The middle column, titled 'Your Next Training Tasks', lists four scenarios: 'Los Angeles VFR Corridor' (0.4 hrs), 'Unfamiliar Airspace' (0.5 hrs), '[Testing] Scoring' (0.5 hrs), and 'Wind Shear On Approach' (0.3 hrs). The right column, titled 'Your Reading List', lists two items: 'Everything You Need to Know About Instrument Rating Requirements' (8 mins) and 'WAAS Approaches: Precision or Non-'. A bottom navigation bar includes icons for Training Plan, ProScore, Scenarios, Skills, Articles, Quizzes, Collections, Log Event, and More.

Image 20: RBPro Main Page

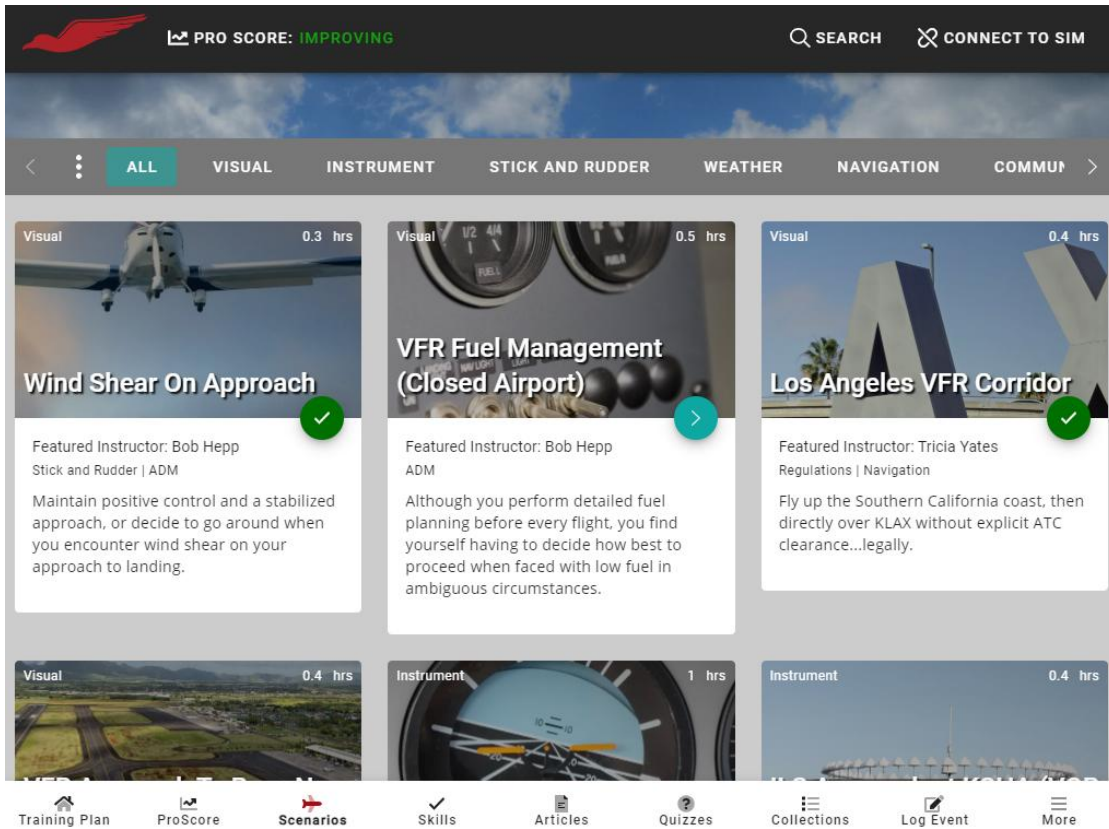

Image 21: Scenario Selection Page

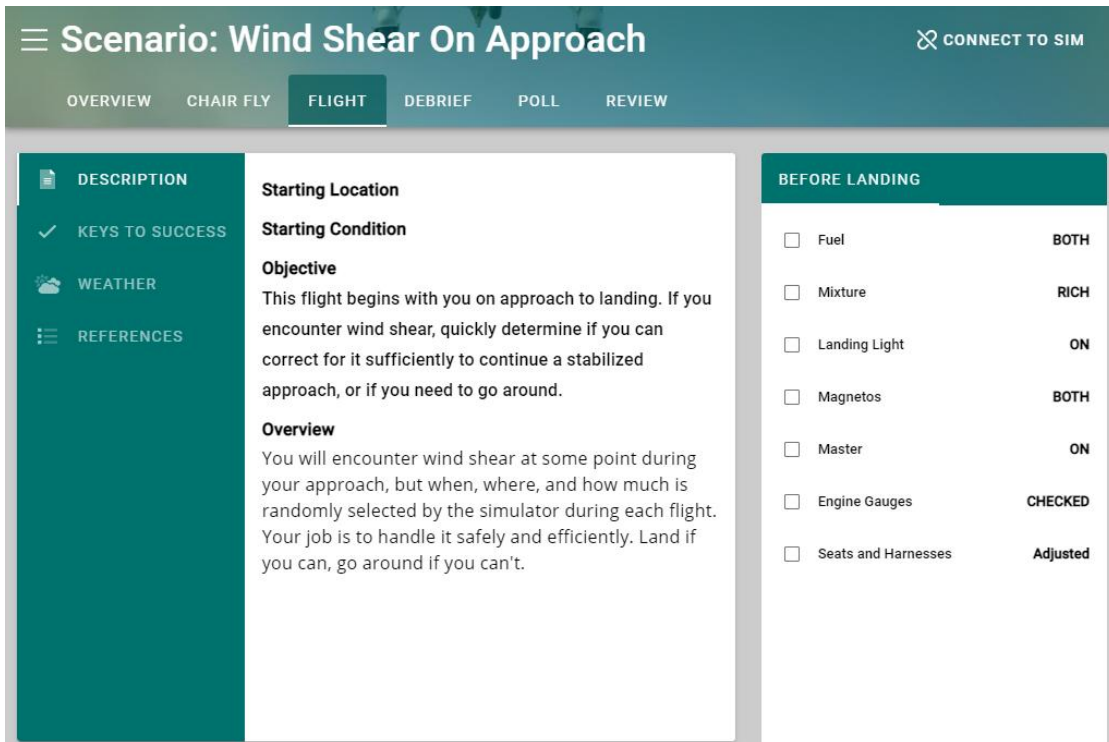

Image 22: Scenario Detail Page

CONNECT

Redbird CONNECT is a connection service that provides secured remote connection to the simulator's Redbird Navigator IOS. CONNECT generates an authentication access code that is used to establish the connection.

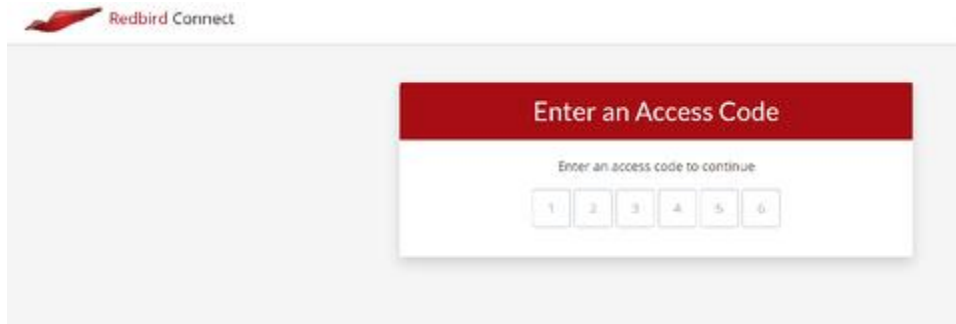

Image 23: CONNECT (SAMPLE access code)

Corvus

Corvus provides Redbird simulator location service to an EFB by providing data similar to an ADS-B receiver. In addition to representing own-ship position of simulated aircraft, Corvus also broadcasts attitude and heading reference systems (AHRS) information as well as Traffic Information Services-Broadcast (TIS-B) data. Select Flight Information Services-Broadcast (FIS-B) functionality, such as weather and airspace information will be added in future updates.

*Corvus runs in the background. No images available.

Cygnus Home/Cygnus Pro

Cygnus connects Apple iOS EFBs with the Redbird simulators. Cygnus Home passes the location of the simulated flight to a specific iOS device through a specialized USB/30pin cable. Cygnus Pro utilizes the Bad Elf device to connect up to 6 iOS device and their aviation app to display the simulated location of the aircraft.



Image 24: Cygnus Pro

Aircraft Instrument Configurations

The Redbird LD, SD, FMX, and MCX simulators are capable of supporting multiple aircraft configurations utilizing both traditional analog instruments as well as glass panels.



Image 25: Traditional 6-pack Instrument Panel Configuration (Example with Center Yoke and T-M Lever Throttle)



Image 26: Glass Panel Instrument Configuration (Example with Center Yoke and T-M Lever Throttle)

The Redbird Cessna 172 and Cessna 182 configurations can be equipped with the Angle of Attack Indicator. When utilized, this places a functional representation of the GI260 angle of attack indicator above the panel as well as relocating the whiskey compass as shown.



Modular Controls

The modular design of the Redbird LD, SD, FMX, and MCX simulators allow for quick configuration changes between single and multi-engine aircraft configurations.



Image 27: Center Yoke



Image 28: Side Yoke



Image 29: Center Stick



Image 30: Dual Yoke (MCX only)



Image 31: Single Engine Vernier Throttle
(Carb Heat optional)



Image 32: Single Engine Complex Vernier Throttle
(Carb Heat optional)

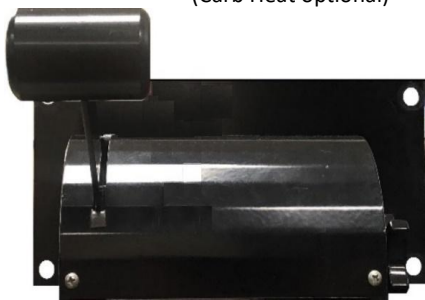

Image 33: Single Engine "Boat Style"
Throttle
(Carb Heat optional)

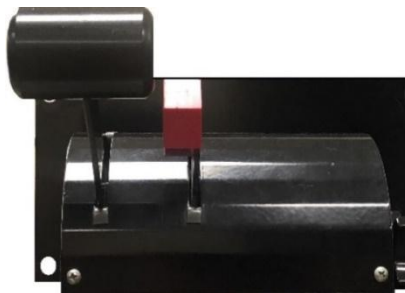

Image 34: Single Engine "Boat Style"
Throttle
(Carb Heat optional)

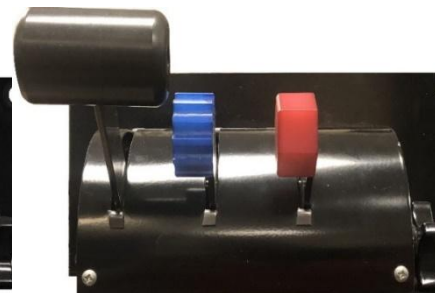

Image 35: Single Engine Complex "Boat Style"
Throttle
(Carb Heat optional)



Image 36: Carb Heat Controls (Optional)



Image 37: Twin Engine Throttle– Type 1



Image 38: Twin Engine Throttle– Type 2

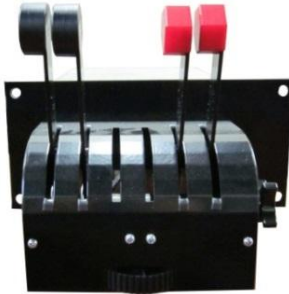

Image 39: Twin Engine Throttle– Type 3

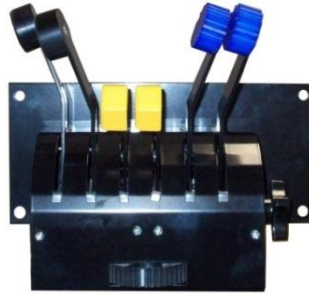

Image 40: Twin Engine Throttle– Type 4



Image 41: Twin Engine Throttle– Type 5



Image 42 & 43: Optional CAPS for Cirrus



Image 44: Left Side of Lower Switch Panel Type 1 & Manual Trim Wheel*

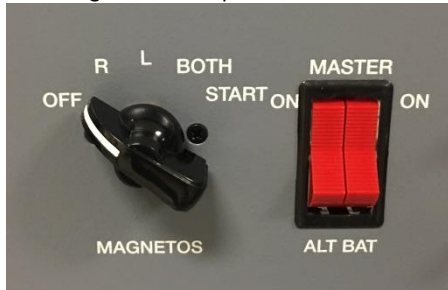

Image 45: Switch Panel 1 Starter Switch*



Image 46: Right Side of Lower Switch Panel Type 1, 2, & 3*



Image 47: Switch Panel 1 Starter Switch*



Image 48: Right Side of Lower Switch Panel Type 1, 2, & 3*



Image 49: Training Session Buttons*



Image 50: Training Session Buttons*



Image 51: Training Session Buttons*



Image 52: COM Volume/Squelch Adjustments*



Image 53: COM Volume/Squelch Adjustments*



Image 54: Lower Left Switch Panel Type 2 & 3*



Image 55: Switch Panel Type 2 & 3 Starter Switches*



Image 56: Right Side of Lower Switch Panel Type 2



Image 57: Switch Panel Type 2 Starter Switches*



Image 58: Switch Panel 1 Dual Starter Retrofit Kit



Image 59: Center of Lower Switch Panel Type 1, 2, & 3



Image 60 Manual Trim Wheel

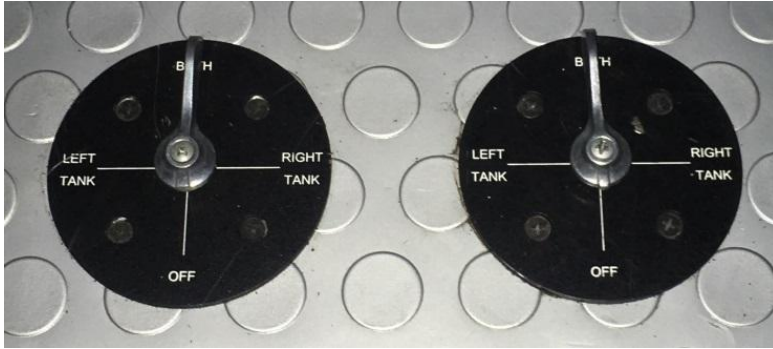

Image 61: Switch Panel 2 & 3 Fuel Selector



Image 62: Switch Panel 1 Fuel Selector

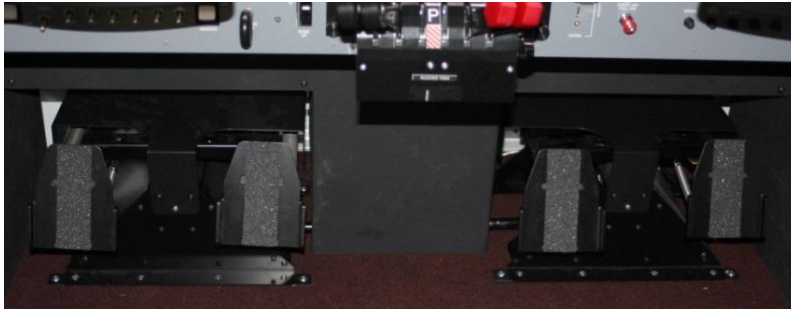

Image 63: Rudder Pedals – Dual

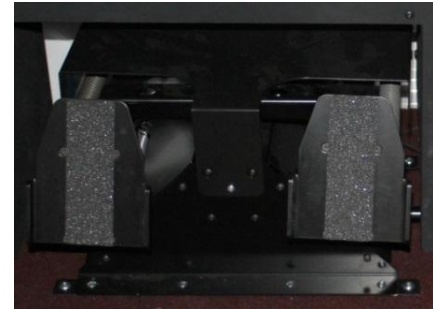

Image 64: Rudder Pedals – Single

*May vary by serial number

SECTION 3: TRAINING DEVICE COMPONENTS LIST

Software Components					
Qty	Type	Manufacturer	Name	Description/Function	Configuration
1	Software	Microsoft	Windows XP, 7, 10, or 11	Operating system. (depending on serial number)	All
1	Software	Microsoft	ESP or FSX	Simulation engine. (depending on serial number)	All
1	Software	Lockheed Martin	Prepar3D	Simulation engine. (depending on serial number)	All
1	Software	Redbird Flight Simulations	RB Sim	Simulation control and component integration. (depending on serial number)	All
1	Software	Redbird Flight Simulations	FMX Control	Motion system control and component integration.	FMX, MCX
1	Software	Redbird Flight Simulations	Instructors Station	Environmental, location and failure controls with map, track and glideslope display. (depending on serial number)	All
1	Software	Redbird Flight Simulations	Navigator	Simulation control and component integration. Environmental, location and failure controls with map, track and glideslope display. (depending on serial number)	All
1	Software	Redbird Flight Simulations	CONNECT	Optional ATD IOS secured remote connection service	All
1	Software	Redbird Flight Simulations	Cygnus (including Pro)	Optional location services software/equipment	All
1	Software	Redbird Flight Simulations	Corvus	Optional location services software	All
1	Software	Redbird Flight Simulations	GIFT (PPL/IR)	Optional guided flight training software	All
1	Software	Redbird Flight Simulations	RBPro	Optional simulator based proficiency program	All
1	Software	PilotEdge	PilotEdge	Optional simulator ATC service	All
1	Software	RealNav Data	Instrument Procedures Database	Provides for FAA published instrument navigation procedures, database per 14 CFR 97 (enroute, approach)	All
1	Software	Mindstar Aviation	Redbird 1000	Virtual replication of the Garmin G1000 flight instruments, GPS, radios, gauges, indicators, alerts, misc. instruments and logic controls for simulated systems.	See Configuration
1	Software	Mindstar Aviation	Redbird 430/ 530	Virtual replication of the Garmin GNS430 and GNS530	See Configuration
1	Software	Mindstar Aviation	Redbird KLN94	Virtual replication of the BendixKing KLN94	See Configuration
1	Software	Mindstar Aviation	Angle of Attack Indicator	Virtual representation of angle of attack indicator	All

1	Software	Mindstar Aviation	Redbird EFD1000	Virtual replication of the Aspen EFD1000	See Configuration
1	Software	Mindstar Aviation	Redbird Entegra	Virtual replication of the Avidyne Entegra flight instruments, radios, gauges, indicators, alerts, misc. instruments and logic controls for simulated systems.	See Configuration
1	Software	Mindstar Aviation	Redbird Autopilot	Virtual replication of the BendixKing KAP140, Genesys STEC55x, and Garmin GFC700 (Redbird 140, 55, or 700)	See Configuration
1	Software	Mindstar Aviation	Redbird Radios	Virtual Radios replication of the BendixKing KX55 and Garmin SL40 (KX155, SL40)	See Configuration
1	Software	Mindstar Aviation	Miscellaneous Gauges	Virtual Miscellaneous Gauges	See Configuration
1	Software	Flight 1	Compass	Virtual Generic Compass	All
1	Software	Redbird Flight Simulations	Analog Gauges	Virtual Airspeed, Attitude, Altimeter, Turn and Bank, Heading, HSI, VSI, RMI, CDI, and ADF Gauges, Radios	See Configuration
1	Software	Redbird Flight Simulations	Miscellaneous Gauges	Virtual Miscellaneous Gauges	All

Table 1: Training Device Component List (Software)

Hardware Components					
Qty	Type	Manufacturer	Name	Description/Function	Configuration
1	Hardware	Redbird Flight Simulations	Simulation Computer	Host computer for flight simulation engine, simulation control software, airplane systems and instruments.	All
1	Hardware	Redbird Flight Simulations	Motion Control Computer	Host computer for FMX Control.	FMX, MCX
1	Hardware	Industry Standard	Instructors Station PC or Wireless Mobile Device	Host computer for Instructors Station.	All
1	Hardware	Redbird Flight Simulations	Motion Platform: Type 1	Gimbaled, steel motion platform with movement in pitch, roll and yaw. Includes all motors, sensors and safety controls.	FMX and MCX configuration - See Image 5,6
1	Hardware	Redbird Flight Simulations	Cockpit Enclosure	Enclosed Flight Deck	FMX, SD, MCX
1	Hardware	Redbird Flight Simulations	Open Enclosure	Open Flight Deck	LD
6	Hardware	22" LCD Industry Standard Monitor	Visual Display - Type 1	Flat Panel displays for exterior views.	All - Varies by configuration
8	Hardware	22" LCD Industry Standard Monitor	Visual Display - Type 2	Optional Flat Panel displays for exterior views.	All - Varies by configuration
6	Hardware	27" LCD Industry Standard Monitor	Visual Display - Type 3	Optional large Flat Panel displays for exterior views.	All - Varies by configuration
8	Hardware	27" LCD Industry Standard Monitor	Visual Display - Type 4	Optional large Flat Panel displays for exterior views.	All - Varies by configuration
2	Hardware	19" LCD Industry Standard Monitor	LCD	Flat Panel displays for virtual instruments.	All
1	Hardware	Redbird Flight Simulations	Yoke, Side Yoke, Center Stick (Single)	Pilot yoke with pitch and roll controller with switches and buttons for airplane systems operation. As required for each configuration.	FMX, SD, LD - Varies by configuration
1	Hardware	Redbird Flight Simulations	Yoke, Side Yoke, Center Stick (Single) - Control Loading	Optional Control loading pilot yoke with pitch and roll controller and switches and buttons for airplane systems operation. As required for each configuration.	FMX, SD, LD - Varies by configuration
1	Hardware	Redbird Flight Simulations	Yoke (Dual) - Control Loading	Control loading pilot and co-pilot yoke with pitch and roll controller with switches and buttons for airplane systems operation. As required for each configuration.	All MCX Configurations
1	Hardware	Redbird Flight Simulations	Throttle Quadrant	As required for each configuration.	All - See Configuration
1	Hardware	Redbird Flight Simulations	Rudder Pedals (Single)	Pilot rudder control pedals with toe brakes.	FMX, SD, LD - Varies by configuration
1	Hardware	Redbird Flight Simulations	Rudder Pedals (Single) - Control Loading	Optional Control loading pilot rudder control pedals with toe brakes.	FMX, SD, LD - Varies by configuration
1	Hardware	Redbird Flight Simulations	Rudder Pedals (Dual)	Pilot and co-pilot rudder control pedals with toe brakes.	MCX - Varies by configuration
1	Hardware	Redbird Flight Simulations	Rudder Pedals (Dual) - Control Loading	Optional Control loading Pilot and co-pilot rudder control pedals with toe brakes.	MCX - Varies by configuration
1	Hardware	Redbird Flight Simulations	Switch Panel: Type 1	Lower switch panel with airplane configuration and systems controls. (depending on serial number)	FMX, SD, LD
1	Hardware	Redbird Flight Simulations	Switch Panel: Type 2	Lower switch panel with airplane configuration and systems controls.	All MCX Configurations
1	Hardware	Redbird Flight Simulations	Switch Panel: Type 3	Lower switch panel with airplane configuration and systems controls. (depending on serial number)	FMX, SD, LD
1	Hardware	Redbird Flight Simulations	Instrument Controls Overlay	Flight instruments, radios, airplane configuration and systems controls as required for each configuration.	All - See Configuration
1	Hardware	Redbird Flight Simulations	Dual Starter Retrofit Kit	Dual Starter, battery, and ALT switches for Switch Panel 1	Optional - FMX, SD, LD
1	Hardware	Redbird Flight Simulations	CAPS	Optional CAPS	All - See Configuration

Table 2: Training Device Component List (Hardware)

SECTION 4: AVIATION TRAINING DEVICE (ATD) DESIGN CRITERIA LIST

The following section provides the detailed “word for word” listing and design criteria of each of the required items, functions, and capabilities (listed in AC 61-136, for BATD requirements Appendix B and the additional AATD items of Appendix C) and operational performance value/scale (as applicable) for each of the functions described for the Redbird LD, SD, FMX, and MCX models.

Basic ATD Requirements List [Appendix B items]

All configurations for this model, as noted, meet AC 61-136, Appendix B requirements

The Redbird LD, SD, FMX, MCX models meets the following Control Input Requirements:

- B.3.1.1 The aircraft physical flight and associated control systems ARE recognizable as to their function and how they are to be manipulated solely from their appearance. These physical flight control systems DO NOT use interfaces such as a keyboard, mouse, or gaming joystick to control the aircraft in simulated flight.
- B.3.1.2 Virtual controls are those controls used to set up certain aspects of the simulation (such as selecting the aircraft configuration, location, weather conditions, etc.) and otherwise program, effect, or pause the training device. These controls ARE part of the instructor station or independent computer interface.
- B.3.1.3 Except for the initial setup, a keyboard or mouse IS not be used to set or position any feature of the ATD flight controls for the maneuvers or training tasks to be accomplished. See the control requirements listed below as applicable to the aircraft model represented. The pilot IS able to operate the controls in the same manner as it would be in the actual aircraft. This includes the landing gear, wing flaps, cowl flaps, carburetor heat, mixture, propeller, and throttle controls appropriate to the aircraft model represented.
- B.3.1.4 The physical arrangement, appearance, and operation of controls, instruments, and switches closely MODELS the aircraft represented. THE REDBIRD LD, SD, FMX, MCX recreates the appearance, arrangement, operation, and function of realistically placed physical switches and other required controls representative of an aircraft instrument panel that includes the following:
 - Master/battery;
 - Magnetos for each engine (as applicable);
 - Alternators or generators for each engine;
 - Auxiliary power unit (APU) (if applicable);
 - Fuel boost pumps/prime boost pumps for each engine;
 - Avionics master;
 - Pitot heat; and
 - Rotating beacon/strobe, navigation, taxi, and landing lights.
- B.3.1.5 ONLY the software evaluated by the FAA may be loaded for use on that computer system. This does not PROHIBIT software updates that do not otherwise change the appearance of the systems operation.

The Redbird LD, SD, FMX, and MCX models meet the following additional airplane physical flight and airplane systems controls:

- B.3.2.1.1 A **self-centering displacement yoke or control stick** that allows continuous adjustment of pitch and bank.
- B.3.2.1.2 **Self-centering rudder pedals** that allow continuous adjustment of yaw and corresponding reaction in heading and roll.
- B.3.2.1.3 **Throttle or power control(s)** that allows continuous movement from idle to full-power settings and corresponding changes in pitch and yaw, as applicable.
- B.3.2.1.4 **Mixture/condition, propeller, and throttle/power control(s)** as applicable to the M/M of aircraft represented.
- B.3.2.1.5 Controls for the following items, as applicable to the category and class of aircraft represented:
 - Wing flaps,
 - Pitch trim,
 - Communication and navigation radios,
 - Clock or timer,

- Gear handle (if applicable),
- Transponder,
- Altimeter,
- Carburetor heat (if applicable), and
- Cowl flaps (if applicable).

The Redbird LD, SD, FMX, and MCX models meet the following Control Input Functionality and Response Criteria:

- B.3.3.1 Time from control input to recognizable system response IS without delay and DOES NOT appear to lag in any way. Redbird Flight Simulations, Inc. verifies that the Redbird LD, SD, FMX, and MCX meets this requirement.
- B.3.3.2 The control inputs ARE tested by the computer and software program at each startup and displayed as a confirmation message of normal operation or a warning message IF the transport delay time or any design parameter is out of tolerance. It IS NOT possible to continue the training session unless the problem is resolved and all components are functioning properly. This test considers all the items listed in the display and control requirements.

The Redbird LD, SD, FMX, and MCX models meet the following Display Requirements:

- B.3.4.1 The following instruments and indicators ARE replicated and properly located as appropriate to the aircraft represented:
- B.3.4.1.1 Flight instruments ARE in a standard configuration representing the traditional “round” dial flight instruments or as an electronic primary flight instrument display (PFD) and multi-function display (MFD) with reversionary and back-up flight instruments.
 - B.3.4.1.2 A sensitive **altimeter** with incremental markings each 20 feet or less, operable throughout the normal operating range of the M/M of aircraft represented.
 - B.3.4.1.3 A **magnetic direction indicator**.
 - B.3.4.1.4 A **heading indicator** with incremental markings each 5 degrees or less, displayed on a 360 degree circle. Arc segments of less than 360 degrees ARE selectively displayed as applicable to the M/M of aircraft represented.
 - B.3.4.1.5 An **airspeed indicator** with incremental markings as shown for the M/M aircraft represented; airspeed markings of less than 20 knots need not be displayed.
 - B.3.4.1.6 A **vertical speed indicator** (VSI) with incremental markings each 100 feet per minute (fpm) for both climb and descent, for the first 1,000 fpm of climb and descent, and at each 500 fpm climb and descent for the remainder of a minimum $\pm 2,000$ fpm total display, or as applicable to the M/M of aircraft being represented.
 - B.3.4.1.7 A **gyroscopic rate-of-turn indicator** or equivalent with appropriate markings for a rate of 3 degrees per second turn for left and right turns. If a turn and bank indicator is used, the 3 degrees per second rate index IS inside of the maximum deflection of the indicator.
 - B.3.4.1.8 A **slip and skid indicator** with coordination information displayed in the conventional inclinometer format where a coordinated flight condition is indicated with the ball in the center position. A split image triangle indication as appropriate for PFD configurations may be used.
 - B.3.4.1.9 An **attitude indicator** with incremental markings each 5 degrees of pitch or less, from 20 degree pitch up to 40 degree pitch down or as applicable to M/M of aircraft represented. Bank angles ARE identified at “wings level” and at 10, 20, 30, and 60 degrees of bank (with an optional additional identification at 45 degrees) in left and right banks.
 - B.3.4.1.10 **Engine instruments** as applicable to the M/M of aircraft being represented, providing markings for the normal ranges including the minimum and maximum limits.
 - B.3.4.1.11 A **suction gauge** or instrument pressure gauge with a display applicable to the aircraft represented.
 - B.3.4.1.12 A **flap setting indicator** that displays the current flap setting. Setting indications should be typical of that found in an actual aircraft.
 - B.3.4.1.13 A **pitch trim indicator** with a display that shows zero trim and appropriate indices of airplane nose down and airplane nose up trim, as would be found in an aircraft.
 - B.3.4.1.14 **Communication radio(s)** with a full range of selectable frequencies displaying the radio frequency in use.

- B.3.4.1.15 **Navigation radio(s)** with a full range of selectable frequencies displaying the frequency in use and capable of replicating both precision and nonprecision instruments, including approach procedures (each with an aural identification feature), and a marker beacon receiver. For example, an instrument landing system (ILS), non-directional radio beacon (NDB), Global Positioning System (GPS), Localizer (LOC) or very high frequency omni-directional range (VOR). Graduated markings as indicated below ARE present on each course deviation indicator (CDI) as applicable. The marking include:
- One-half dot or less for course/glideslope (GS) deviation (i.e., VOR, LOC, or ILS), and
 - Five degrees or less for bearing deviation for automatic direction finder (ADF) and radio magnetic indicator (RMI), as applicable.
 - If equipped with a Primary Flight Display (PFD) and/or Multifunction Flight Display (MFD), the flight and navigation information and guidance replicates the avionics manufactures same scales and navigation information presentation.
- B.3.4.1.16 A clock with incremental markings for each minute and second, or a timer with a display of minutes and seconds.
- B.3.4.1.17 A transponder that displays the current transponder code.
- B.3.4.1.18 A fuel quantity indicator(s) that displays the fuel remaining, either in analog or digital format, appropriate for M/M of aircraft represented.
- B.3.4.2 All instrument displays listed above ARE visible during all flight operations. Allowances can be made for multifunction electronic displays that may not display all instruments simultaneously. All of the displays must provide an image of the instrument that is clear and:
- B.3.4.2.1 Does not appear to be out of focus or illegible.
 - B.3.4.2.2 Does not appear to “jump” or “step” during operation.
 - B.3.4.2.3 Does not appear with distracting jagged lines or edges.
 - B.3.4.2.4 Does not appear to lag relative to the action and use of the flight controls.
- B.3.4.3 Control inputs ARE PROPERLY reflected by the flight instruments in real time and without a perceived delay in action. Display updates must show all changes (within the total range of the replicated instrument) that are equal to or greater than the values stated below:
- B.3.4.3.1 Airspeed indicator: change of 5 knots.
 - B.3.4.3.2 Attitude indicator: change of 2 degrees in pitch and bank.
 - B.3.4.3.3 Altimeter: change of 10 feet.
 - B.3.4.3.4 Turn and bank: change of ¼ standard rate turn.
 - B.3.4.3.5 Heading indicator: change of 2 degrees.
 - B.3.4.3.6 VSI: change of 100 fpm.
 - B.3.4.3.7 Tachometer: change of 25 rpm or 2 percent of turbine speed.
 - B.3.4.3.8 VOR/ILS: change of 1 degree for VOR or ¼ of 1 degree for ILS.
 - B.3.4.3.9 ADF: change of 2 degrees.
 - B.3.4.3.10 GPS: change as appropriate for the model of GPS-based navigator represented.
 - B.3.4.3.11 Clock or timer: change of 1 second.

Note: Airplane configurations with PFD and/or MFD displays are representative of those avionics systems and the associated instrument display information.

- B.3.4.4 Displays must reflect the dynamic behavior of an actual aircraft (e.g., a VSI reading of 500 fpm must reflect a corresponding movement in altitude, and an increase in power must reflect an increase in the rpm indication or power indicator.)

The Redbird LD, SD, FMX, and MCX models meet the following (Flight Dynamics Requirements):

- B.3.5.1 Flight dynamics of the ATD ARE comparable to the way the represented training aircraft performs and handles. However, there is no requirement for an ATD to have control loading to exactly replicate any particular aircraft.
- B.3.5.2 Aircraft performance parameters (such as maximum speed, cruise speed, stall speed, maximum climb rate, and hovering/sideward/forward/rearward flight) ARE comparable to the aircraft being represented. A performance table IS included in the QAG for each aircraft configuration for sea level and 5,000 feet using standard atmosphere and gross weight conditions, to verify the appropriate performance. An alternate performance altitude for 6,000 feet can be used if the manufacturer of that aircraft has a performance chart reflecting that altitude. Performance at altitude for turboprop or turbojet configurations should reflect 18,000 ft.

- B.3.5.3 Aircraft vertical lift component CHANGES as a function of bank comparable to the way the aircraft being represented performs and handles.
- B.3.5.4 Changes in flap setting, slat setting, gear position, collective control, or cyclic control ARE accompanied by changes in flight dynamics comparable to the way the M/M of aircraft represented performs and handles.
- B.3.5.5 The presence and intensity of wind and turbulence ARE reflected in the handling and performance qualities of the simulated aircraft and IS comparable to the way the aircraft represented performs and handles.

The Redbird LD, SD, FMX, and MCX models meet the following Instructional Management Requirements:

- B.3.6.1 The instructor IS able to pause the system at any time during the training simulation for the purpose of administering instruction or procedural recommendations.
- B.3.6.2 If a training session begins with the “aircraft in the air” and ready for the performance of a particular procedural task, the instructor IS able to manipulate the following system parameters independently of the simulation:
 - Aircraft geographic location,
 - Aircraft heading,
 - Aircraft airspeed,
 - Aircraft altitude, and
 - Wind direction, speed, and turbulence.
- B.3.6.3 The system IS capable of recording both a horizontal and vertical track of aircraft movement during the entire training session for later playback and review.
- B.3.6.4 The instructor IS able to disable any of the instruments prior to or during a training session and IS able to simulate failure of any of the instruments without stopping or freezing the simulation to affect the failure. This includes simulated engine failures and the following aircraft systems failures: alternator or generator, vacuum or pressure pump, pitot static, electronic flight displays, or landing gear or flaps, as appropriate.
- B.3.6.5 The ATD HAS a navigational area database that is local (25 nautical miles (NM)) to the training facility to allow reinforcement of procedures learned during actual flight in that area. All navigational data ARE based on procedures as published per 14 CFR part 97. This device uses Navigraph or RealNav Data to support the instrument approach and navigation capabilities.

Advanced ATD Requirements List [Appendix C items]

All configurations, as noted in AC 61-136, Appendix C meet these additional AATD design criteria items listed.

The Redbird LD, SD, FMX, and MCX models meet the following additional AATD CRITERIA:

- C.3.1.1 A realistic shrouded (enclosed) or unshrouded (open) cockpit design and instrument panel arrangement representing a specific model aircraft cockpit.
- C.3.1.2 Cockpit knobs, system controls, switches, and/or switch panels in realistic sizes and design appropriate to each intended functions, in the proper position and distance from the pilot's seated position, and representative of the category and class of aircraft being represented.
- C.3.1.3 Primary flight and navigation instruments appropriately sized and properly arranged that exhibit neither stepping nor excessive transport delay.
- C.3.1.4 **Digital Avionics Panel**
- C.3.1.5 Global Positioning System (**GPS**) **navigator** with moving map display.
- C.3.1.6 **Two-axis autopilot**, and, as appropriate, a flight director (FD). This is only required when an autopilot is original standard equipment from the aircraft manufacturer.
- C.3.1.7 **Pitch trim** (manual or electric pitch trim) IS AVAILABLE permitting indicator movement either electrically or analog in an acceptable trim ratio.
- C.3.1.8 An **independent visual system**, panel, or screen that provides realistic cues in both day and night visual flight rules (VFR) and instrument flight rules (IFR) meteorological conditions to enhance a pilot's visual orientation in the vicinity of an airport including:
 - Adjustable visibility parameters; and
 - Adjustable ceiling parameters.
- C.3.1.9 A fixed pilot seat appropriate to the aircraft configuration, including an adjustable height and an adjustable forward and aft seat position.
- C.3.1.10 **Rudder pedals** secured to the cockpit floor structure, or that can be physically secured to the floor beneath the device in proper relation to cockpit orientation.
- C.3.1.11 **Push-to-talk switch** on the control yoke.
- C.3.1.12 A **separate instructor station** PERMITTING effective interaction without interrupting the flight in overseeing the pilot's horizontal and vertical flight profiles in real time and space. This must include the ability to:
 1. Oversee tracks along airways, holding entries and patterns, and Localizer (LOC) and glideslope (GS) alignment/deviation (or other approaches with a horizontal and vertical track).
 2. Function as air traffic control (ATC) in providing vectors, etc., change in weather conditions, ceilings, visibilities, wind speed and direction, light/moderate/severe turbulence, and icing conditions.
 3. Invoke failures in navigation and instruments, radio receivers, landing gear and flaps, engine power (partial and total), and other aircraft systems (pitot, electric, static, etc.) by using either a keyboard or mouse.

The Redbird LD, SD, FMX, and MCX models meet the following additional encouraged (not required) AATD CRITERIA:

- C.3.2.1 Multi-panel or wrap-around visual system providing a 120 degrees or more of horizontal vision.
- C.3.2.2 Automated ATC communications, scenario-based training (SBT), or line-oriented type training in which the instructor can evaluate pilot performance without having to act as ATC.
- C.3.2.3 Simulated loss of performance and aerodynamic changes from ice accretion.
- C.3.2.4 Realistic aircraft engine sound appropriate to the aircraft configuration, power settings, and speed.
- C.3.2.5 A magnetic compass with incremental markings each 5 degrees, that displays the proper lead or lag during turns, and displays incremental markings typical of that shown in the aircraft.

SECTION 5: AIRCRAFT CONFIGURATIONS

List of Previously Approved Configurations: Beechcraft BE36-S1



- Yoke – Center (See Image 27 & 30)
- Throttle – Single Engine Complex Lever (T-P-M) (See Image 35)
- Traditional analog gauges & GNS430/530 GPS with KAP140 Autopilot

Beechcraft BE36-G1



- Yoke – Center (See Image 27 & 30)
- Throttle – Single Engine Complex Lever (T-P-M) (See Image 35)
- Glass Cockpit G1000 PFD/MFD & GFC700 Autopilot

Beechcraft BE55-G1

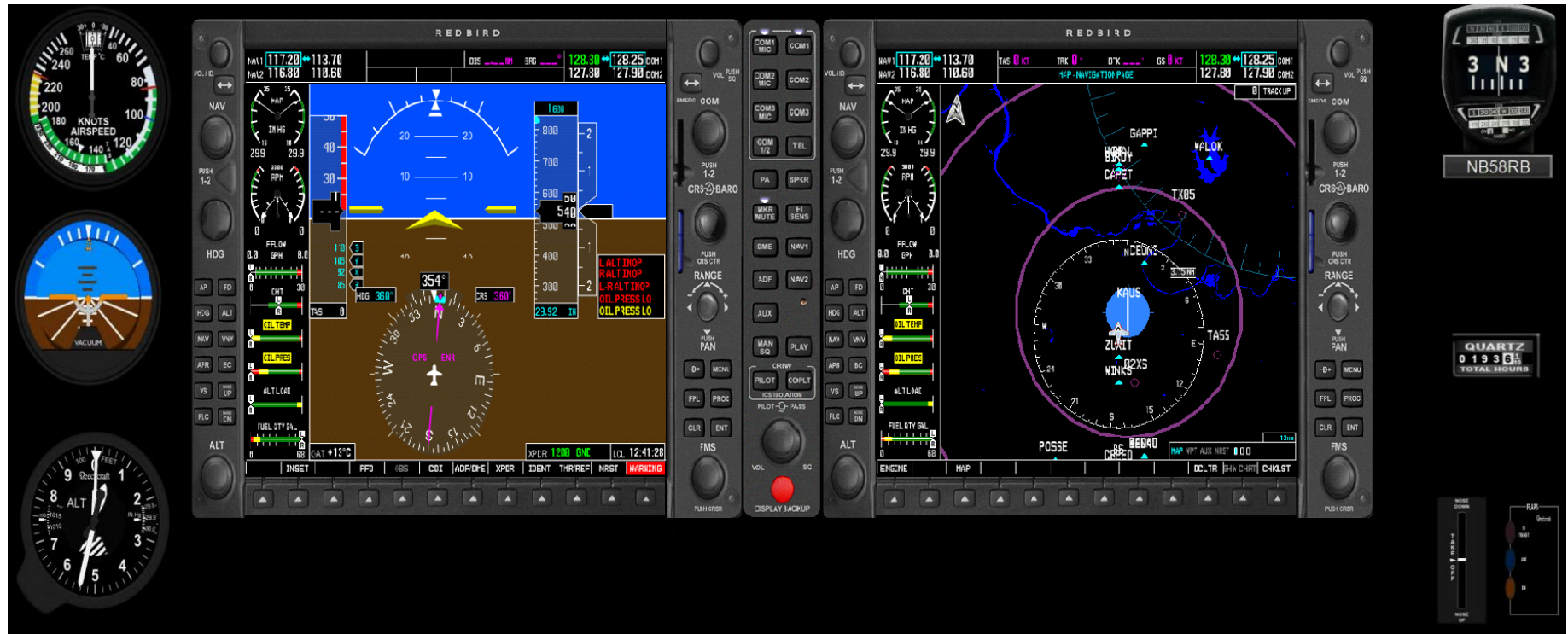

- Yoke – Center (See Image 27 & 30)
- Throttle – Twin Engine Complex Lever (TT-MM-PP) (See Image 38)
- Glass Cockpit G1000 PFD/MFD & GFC700 Autopilot

Beechcraft BE55-S1



- Yoke – Center (See Image 27 & 30)
- Throttle – Twin Engine Complex Lever (PP-TT-MM) (See Image 38)
- Traditional analog gauges & GNS430/530 GPS with KAP140 Autopilot

Beechcraft BE58-S1



- Yoke – Center (See Image 27 & 30)
- Throttle – Twin Engine Complex Lever (PP-TT-MM) (See Image 38)
- Traditional analog gauges & GNS430/530 GPS with KAP140 Autopilot

Beechcraft BE58-S2



- Yoke – Center (See Image 27 & 30)
- Throttle – Twin Engine Complex Lever (TT-PP-MM) (See Image 37)
- Traditional analog gauges & GNS430/530 GPS with KAP140 Autopilot

Beechcraft BE58-G1

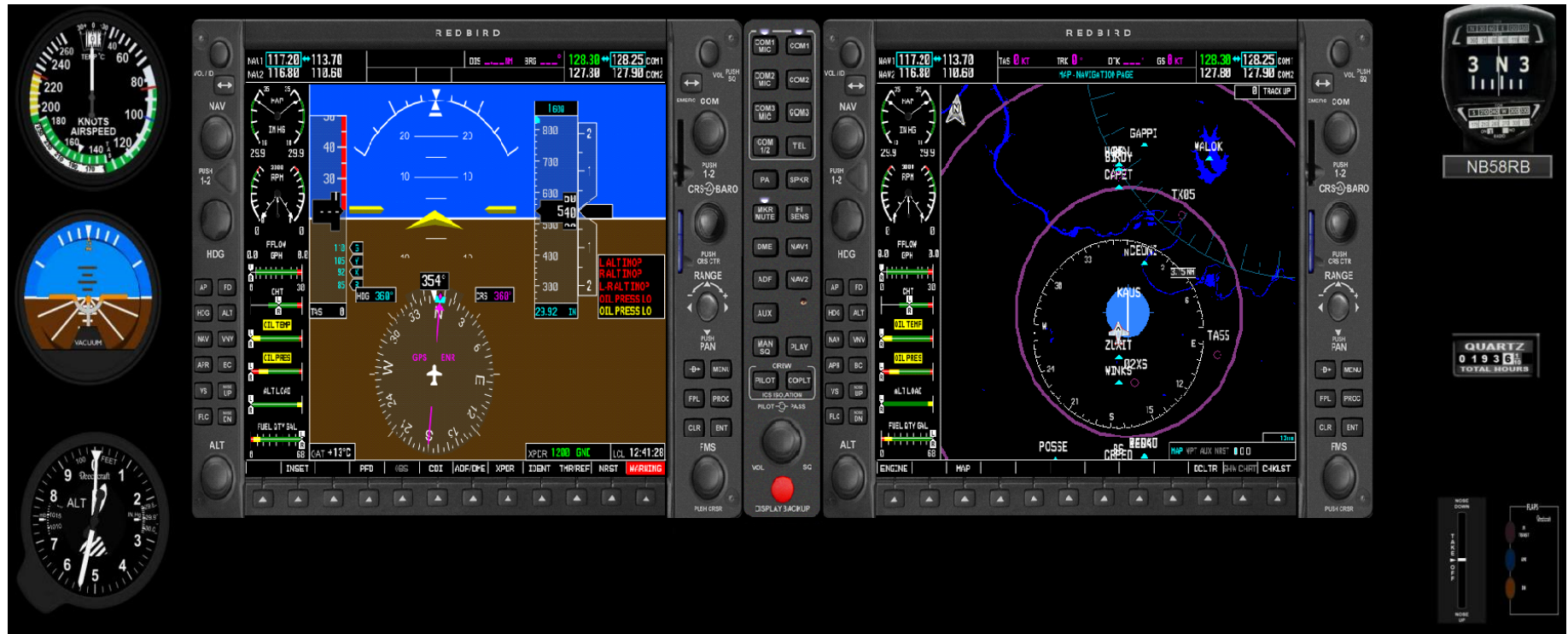

- Yoke – Center (See Image 27 & 30)
- Throttle – Twin Engine Complex Lever (TT-PP-MM) (See Image 37)
- Glass Cockpit G1000 PFD/MFD & GFC700 Autopilot

Beechcraft BE76-S1



- Yoke – Center (See Image 27 & 30)
- Throttle – Twin Engine Complex Lever (TT-PP-MM) (See Image 37)
- Traditional analog gauges & GNS430/530 GPS with KAP140 Autopilot

Cessna C172-S1



- Yoke – Center (See Image 27 & 30)
- Throttle – Single Engine Vernier (T-M) (See Image 31)
- Traditional analog gauges & GNS430/530 GPS with KAP140 Autopilot

Cessna C172-S2



- Yoke – Center (See Image 27 & 30)
- Throttle – Single Engine Vernier (T-M) (See Image 31)
- Traditional analog gauges & KLN94 GPS with KAP140 Autopilot

Cessna C172-G1



- Yoke – Center (See Image 27 & 30)
- Throttle – Single Engine Vernier (T-M) (See Image 31)
- Glass Cockpit G1000 PFD/MFD & KAP140 Autopilot

Cessna C172-G2



- Yoke – Center (See Image 27 & 30)
- Throttle – Single Engine Vernier (T-M) (See Image 31)
- Glass Cockpit G1000 PFD/MFD & GFC700 Autopilot

Cessna C172RG-S1



- Yoke – Center (See Image 27 & 30)
- Throttle – Single Engine Complex Vernier (T-P-M) (See Image 32)
- Traditional analog gauges & GNS430/530 GPS with KAP140 Autopilot

Cessna C172RG-G2



- Yoke – Center (See Image 12 & 15)
- Throttle – Single Engine Complex Vernier (T-P-M) (See Image 17)
- Glass Cockpit G1000 PFD/MFD & GFC700 Autopilot

Cessna C172RG-S2



- Yoke – Center (See Image 27 & 30)
- Throttle – Single Engine Complex Vernier (T-P-M) (See Image 32)
- Traditional analog gauges & KLN94 GPS with KAP140 Autopilot

Cessna C182-S1



- Yoke – Center (See Image 27 & 30)
- Throttle – Single Engine Complex Vernier (T-P-M) (See Image 32)
- Traditional analog gauges & GNS430/530 GPS with KAP140 Autopilot

Cessna C182-S2



- Yoke – Center (See Image 27 & 30)
- Throttle – Single Engine Complex Vernier (T-P-M) (See Image 32)
- Traditional analog gauges & KLN94 GPS with KAP140 Autopilot

Cessna C182-G1



- Yoke – Center (See Image 27 & 30)
- Throttle – Single Engine Complex Vernier (T-P-M) (See Image 32)
- Glass Cockpit G1000 PFD/MFD & KAP140 Autopilot

Cessna C182-G2



- Yoke – Center (See Image 27 & 30)
- Throttle – Single Engine Complex Vernier (T-P-M) (See Image 32)
- Glass Cockpit G1000 PFD/MFD & GFC700 Autopilot

Cessna C182RG-S1



- Yoke – Center (See Image 27 & 30)
- Throttle – Single Engine Complex Vernier (T-P-M) (See Image 32)
- Traditional analog gauges & GNS430/530 GPS with KAP140 Autopilot

Cessna C182RG-S2



- Yoke – Center (See Image 27 & 30)
- Throttle – Single Engine Complex Vernier (T-P-M) (See Image 32)
- Traditional analog gauges, KLN94 GPS with KAP140 Autopilot

Cessna C182RG-G2



- Yoke – Center (See Image 27 & 30)
- Throttle – Single Engine Complex Vernier (T-P-M) (See Image 32)
- Glass Cockpit G1000 PFD/MFD & GFC700 Autopilot

Cessna C206-S1



- Yoke – Center (See Image 27 & 30)
- Throttle – Single Engine Complex Vernier (T-P-M) (See Image 32)
- Traditional analog gauges & GNS430/530 GPS with KAP140 Autopilot

Cessna C206-S2



- Yoke – Center (See Image 27 & 30)
- Throttle – Single Engine Complex Vernier (T-P-M) (See Image 32)
- Traditional analog gauges & KLN94 GPS with KAP140 Autopilot

Cessna C206-G1



- Yoke – Center (See Image 27 & 30)
- Throttle – Single Engine Complex Vernier (T-P-M) (See Image 32)
- Glass Cockpit G1000 PFD/MFD & KAP140 Autopilot

Cessna C206-G2



- Yoke – Center (See Image 27 & 30)
- Throttle – Single Engine Complex Vernier (T-P-M) (See Image 32)
- Glass Cockpit G1000 PFD/MFD & GFC700 Autopilot

Cessna C206T-S1



- Yoke – Center (See Image 27 & 30)
- Throttle – Single Engine Complex Lever (T-P-M) (See Image 35)
- Traditional analog gauges & GNS430/530 GPS with KAP140 Autopilot

Cirrus SR20-G1



- Yoke – Left (See Image 28)
- Throttle – Single Engine Lever (T-M) (See Image 34)
- Glass Cockpit Entegra PFD/MFD & Dual GNS430 GPS with STEC55 Autopilot

Cirrus SR20-G2



- Yoke – Left (See Image 28)
- Throttle – Single Engine Lever (T-M) (See Image 34)
- Glass Cockpit Perspective PFD/MFD & FMS Keypad with Perspective Autopilot

Cirrus SR22-G1



- Yoke – Left (See Image 28)
- Throttle – Single Engine Lever (T-M) (See Image 34)
- Glass Cockpit Entegra PFD/MFD & Dual GNS430 GPS with STEC55 Autopilot

Cirrus SR22-G2



- Yoke – Left (See Image 28)
- Throttle – Single Engine Lever (T-M) (See Image 34)
- Glass Cockpit Perspective PFD/MFD & FMS Keypad with Perspective Autopilot

Diamond DA20-S1



- Yoke – Stick (See Image 29)
- Throttle – Single Engine Lever (T-M) (See Image 34)
- Traditional analog gauges & GNS430 GPS with STEC55 Autopilot

Diamond DA40NG-1



- Yoke – Stick (See Image 29)
- Throttle – Single Engine Complex Lever (T-P-M) (See Image 35)
- Glass Cockpit G1000 PFD/MFD & GFC700 Autopilot

Diamond DA40-G1



- Yoke – Stick (See Image 29)
- Throttle – Single Engine Complex Lever (T-P-M) (See Image 35)
- Glass Cockpit G1000 PFD/MFD & GFC700 Autopilot

Diamond DA40-G2



- Yoke – Stick (See Image 29)
- Throttle – Single Engine Complex Lever (T-P-M) (See Image 35)
- Glass Cockpit G1000 PFD/MFD & KAP140 Autopilot

Diamond DA42-G1



- Yoke – Stick (See Image 29)
- Throttle – Twin Engine Lever (TT-MM) (See Image 39)
- Glass Cockpit G1000 PFD/MFD & GFC700 Autopilot

Diamond DA42-G2



- Yoke – Stick (See Image 29)
- Throttle – Twin Engine Lever (TT-MM) (See Image 39)
- Glass Cockpit G1000 PFD/MFD & KAP140 Autopilot

This page intentionally left blank.

Diamond DA42L-G2



- Yoke – Stick (See Image 29)
- Throttle – Twin Engine Lever (TT-PP-MM) (See Image 37)
- Glass Cockpit G1000 PFD/MFD & KAP140 Autopilot

Maul MX7-180B



- Yoke – Center (See Image 27)
- Throttle – Single Engine Complex Vernier (T-P-M) (See Image 32)
- Traditional analog gauges & 430/530 GPS with KAP140 Autopilot

Mooney M20-G1



- Yoke – Stick (See Image 29)
- Throttle – Single Engine Complex Lever (T-P-M) (See Image 35)
- Glass Cockpit G1000 PFD/MFD & GFC700 Autopilot

Piper Warrior PA28-60-S1



- Yoke – Center (See Image 27 & 30)
- Throttle – Single Engine Lever (T-M) (See Image 34)
- Traditional analog gauges & Dual GNS430 GPS with STEC55 Autopilot

Piper Warrior PA28-60-S2



- Yoke – Center (See Image 27 & 30)
- Throttle – Single Engine Lever (T-M) (See Image 34)
- Traditional analog gauges & GNS430/530 GPS with KAP140 Autopilot

Piper Warrior PA28-60-G1



- Yoke – Center (See Image 27 & 30)
- Throttle – Single Engine Lever (T-M) (See Image 34)
- Glass Cockpit Entegra PFD/MFD & Dual GNS430 GPS with STEC55 Autopilot

Piper Archer PA28-80-S1



- Yoke – Center (See Image 27 & 30)
- Throttle – Single Engine Lever (T-M) (See Image 34)
- Traditional analog gauges & Dual GNS430 GPS with STEC55 Autopilot

Piper Archer PA28-80-S2



- Yoke – Center (See Image 27 & 30)
- Throttle – Single Engine Lever (T-M) (See Image 34)
- Traditional analog gauges & GNS430/530 GPS with KAP140 Autopilot

Piper Archer PA28-80-G1



- Yoke – Center (See Image 27 & 30)
- Throttle – Single Engine Lever (T-M) (See Image 34)
- Glass Cockpit G1000 PFD/MFD & GFC700 Autopilot

This page intentionally left blank.

Piper Arrow PA28-2R-S1



- Yoke – Center (See Image 27 & 30)
- Throttle – Single Engine Complex Lever (T-P-M) (See Image 35)
- Traditional analog gauges & Dual GNS430 GPS with STEC55 Autopilot

Piper Arrow PA28-2R-S2



- Yoke – Center (See Image 27 & 30)
- Throttle – Single Engine Complex Lever (T-P-M) (See Image 35)
- Traditional analog gauges & GNS430/530 GPS with KAP140 Autopilot

Piper Arrow PA28-2R-G1



- Yoke – Center (See Image 27 & 30)
- Throttle – Single Engine Complex Lever (T-P-M) (See Image 35)
- Glass Cockpit Entegra PFD/MFD & Dual GNS430 GPS with STEC55 Autopilot

Piper Arrow PA28-2R-G2



- Yoke – Center (See Image 27 & 30)
- Throttle – Single Engine Complex Lever (T-P-M) (See Image 35)
- Glass Cockpit G1000 PFD/MFD & GFC700 Autopilot

Piper Seneca PA34-S1



- Yoke – Center (See Image 27 & 30)
- Throttle – Twin Engine Complex Lever (TT-PP-MM) (See Image 37)
- Traditional analog gauges & GNS430/530 GPS with KAP140 Autopilot

Piper Seneca PA34-G1

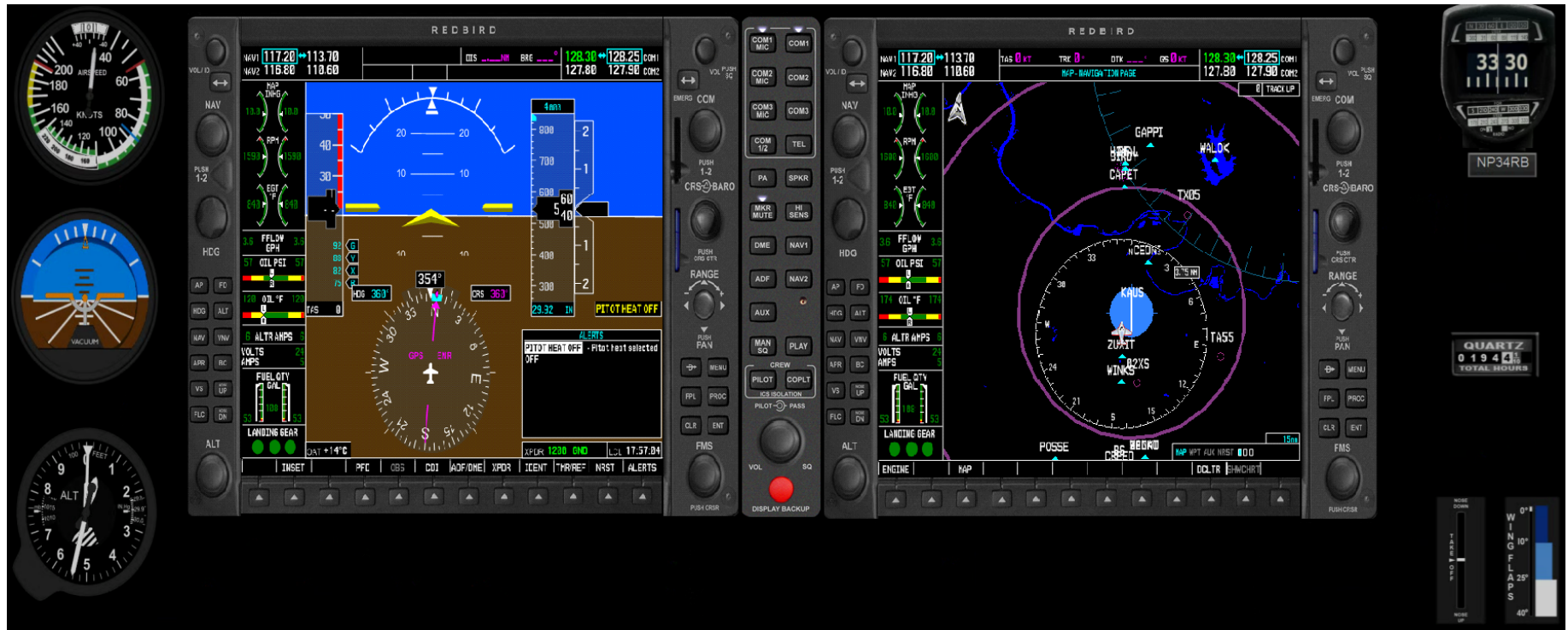

- Yoke – Center (See Image 27 & 30)
- Throttle – Twin Engine Complex Lever (TT-PP-MM) (See Image 37)
- Glass Cockpit G1000 PFD/MFD & GFC700 Autopilot

Piper Seneca PA34T-S1



- Yoke – Center (See Image 27 & 30)
- Throttle – Twin Engine Complex Lever (TT-PP-MM) (See Image 37)
- Traditional analog gauges & GNS430/530 GPS with KAP140 Autopilot

Piper Seneca PA34T-G1



- Yoke – Center (See Image 27 & 30)
- Throttle – Twin Engine Complex Lever (TT-PP-MM) (See Image 37)
- Glass Cockpit G1000 PFD/MFD & GFC700 Autopilot

Piper Tomahawk PA38-S2



- Yoke – Center (See Image 27 & 30)
- Throttle – Single Engine Lever (T-M) (See Image 34)
- Traditional analog gauges & GNS430/530 GPS with KAP140 Autopilot

Piper Seminole PA44-S1



- Yoke – Center (See Image 27 & 30)
- Throttle – Twin Engine Complex Lever (TT-PP-MM) (See Image 37)
- Traditional analog gauges & GNS430/530 GPS with KAP140 Autopilot

Piper Seminole PA44-G1



- Yoke – Center (See Image 27 & 30)
- Throttle – Twin Engine Complex Lever (TT-PP-MM) (See Image 37)
- Glass Cockpit G1000 PFD/MFD & GFC700 Autopilot

Piper Seminole PA44T-S1



- Yoke – Center (See Image 27 & 30)
- Throttle – Twin Engine Complex Lever (TT-PP-MM) (See Image 37)
- Traditional analog gauges & GNS430/530 GPS with KAP140 Autopilot

Socata TB10-S1



- Yoke – Center (See Image 27 & 30)
- Throttle – Single Engine Complex Vernier (T-P-M) (See Image 32)
- Traditional analog gauges & GNS430/530 GPS with KAP140 Autopilot

Tecnam P2006-G1



- Yoke – Center (See Image 27 & 30)
- Throttle – Twin Engine Lever (TT-CC-PP / TT-PP-CC) (See Image 40/41)
- Glass Cockpit G1000 PFD/MFD & STEC55 Autopilot

Tecnam P2010-G1



- Yoke – Center (See Image 27 & 30)
- Throttle – Single Engine Lever (T-M) (See Image 34)
- Glass Cockpit G1000 PFD/MFD & GFC700

Additional configurations included in this version:

Piper Archer PA28-80-G2



- Yoke – Stick (See Image 14)
- Throttle – Single Engine Lever (T-M) (See Image 18)
- Glass Cockpit G1000 PFD/EFD1000 & GFC700 Autopilot

This page intentionally left blank.

This page intentionally left blank.

Performance Table

Single-Engine Performance

Aircraft Model	V _{SO}	V _{S1}	V _X	V _Y	V _A	V _{NE}	V _G	V _{MCA}	KTAS @ Cruise / 75% power setting	Rate of Climb (fpm) @ (V _Y) / Full Power	Single Engine Rate of Climb (V _{YSE})
Beechcraft (A36) Bonanza	53 KIAS	62 KIAS	78 KIAS	96 KIAS	140 KIAS	204 KIAS	110 KIAS	N/A	160 KTAS	1030 fpm	N/A
5000' -->									166 KTAS	740 fpm	N/A
Cessna 172 Skyhawk	40 KIAS	48 KIAS	56 KIAS	74 KIAS	105 KIAS	163 KIAS	68 KIAS	N/A	116 KTAS	730 fpm	N/A
5000' -->									119 KTAS	550 fpm	N/A
Cessna 172RG Cutlass RG	42 KIAS	50 KIAS	67* KIAS	84 KIAS	106 KIAS	164 KIAS	73 KIAS	N/A	131 KTAS	800 fpm	N/A
5000' -->									134 KTAS	590 fpm	N/A
Cessna 182 Skylane	35 KIAS	40 KIAS	58 KIAS	80 KIAS	110 KIAS	175 KIAS	75 KIAS	N/A	129 KTAS	925 fpm	N/A
5000' -->									135 KTAS	705 fpm	N/A
Cessna 182RG Skylane RG	39 KIAS	41 KIAS	65 KIAS	88 KIAS	112 KIAS	181 KIAS	80 KIAS	N/A	148 KTAS	1140 fpm	N/A
5000' -->									152 KTAS	778 fpm	N/A
Cessna 206 Stationair	34 KIAS	41 KIAS	65 KIAS	84 KIAS	120 KIAS	183 KIAS	75 KIAS	N/A	141 KTAS	920 fpm	N/A
5000' -->									145 KTAS	640 fpm	N/A
Cessna 206 Stationair TC	39 KIAS	50 KIAS	74 KIAS	87 KIAS	125 KIAS	182 KIAS	80 KIAS	N/A	139 KTAS	1050 fpm	N/A
5000' -->									144 KTAS	955 fpm	N/A
Cirrus SR20	56 KIAS	65 KIAS	75 KIAS	85 KIAS	131 KIAS	200 KIAS	96 KIAS	N/A	147 KTAS	828 fpm	N/A
5000' -->									151 KTAS	566 fpm	N/A
Cirrus SR22	59 KIAS	70 KIAS	78 KIAS	91 KIAS	133 KIAS	201 KIAS	88 KIAS	N/A	170 KTAS	1304 fpm	N/A
5000' -->									175 KTAS	1015 fpm	N/A
Diamond DA20	37 KIAS	41 KIAS	57 KIAS	65 KIAS	104 KIAS	161 KIAS	72 KIAS	N/A	98 KTAS	675 fpm	N/A
5000' -->									108 KTAS	440 fpm	N/A

Diamond DA40	49 KIAS	52 KIAS	66 KIAS	66 KIAS	108 KIAS	178 KIAS	73 KIAS	N/A	128 KTAS	1100 fpm	N/A
5000' -->									136 KTAS	720 fpm	N/A
Diamond DA40NG	57 KIAS	61 KIAS	67 KIAS	72 KIAS	108 KIAS	172 KIAS	88 KIAS	N/A	125KTAS	800 fpm	N/A
5000' -->									129 KTAS	756 fpm	N/A
Maul MX7-180B	41 KIAS	53 KIAS	65 KIAS	78 KIAS	109 KIAS	161 KIAS	72 KIAS	N/A	120 KTAS	1000 fpm	N/A
5000' -->									125 KTAS	800 fpm	N/A
Mooney M20TN (Type S)	61 KIAS	67 KIAS	84 KIAS	104 KIAS	127 KIAS	194 KIAS	92 KIAS	N/A	182 KTAS	1375 fpm	N/A
5000' -->									197 KTAS	1275 fpm	N/A
Piper PA-28-161 Warrior III	44 KIAS	50 KIAS	53 KIAS	79 KIAS	111 KIAS	160 KIAS	73 KIAS	N/A	106 KTAS	644 fpm	N/A
5000' -->									114 KTAS	396 fpm	N/A
Piper PA-28-181 Archer III	45 KIAS	50 KIAS	60 KIAS	76 KIAS	113 KIAS	154 KIAS	76 KIAS	N/A	121 KTAS	680 fpm	N/A
5000' -->									125 KTAS	480 fpm	N/A
Piper PA-28R-201 Arrow	55 KIAS	60 KIAS	60 KIAS	90 KIAS	118 KIAS	183 KIAS	79 KIAS	N/A	131 KTAS	840 fpm	N/A
5000' -->									135 KTAS	580 fpm	N/A
Piper PA-38-112 Tomahawk	46 KIAS	48 KIAS	61 KIAS	70 KIAS	103 KIAS	138 KIAS	70 KIAS	N/A	99 KTAS	710 fpm	N/A
5000' -->									105 KTAS	460 fpm	N/A
Socata TB10	53 KIAS	60 KIAS	65 KIAS	78 KIAS	122 KIAS	165 KIAS	86 KIAS	N/A	119 KTAS	787 fpm	N/A
5000' -->									124 KTAS	525 fpm	N/A
Tecnam P2010	50 KIAS	59 KIAS	76 KIAS	82 KIAS	120 KIAS	166 KIAS	85 KIAS	N/A	121 KTAS	713 fpm	N/A
5000' -->									126 KTAS	510 fpm	N/A

*Gear Up

Table 3: Performance (Single-Engine)

Multi-Engine Performance

Aircraft Model	V _{SO}	V _{S1}	V _X	V _Y	V _A	V _{NE}	V _G	V _{MCA}	KTAS @ Cruise / 75% power setting	Rate of Climb (fpm) @ (V _Y) / Full Power	Single Engine Rate of Climb (V _{YSE})
Beechcraft (BE55) Baron	73 KIAS	79 KIAS	91 KIAS	107 KIAS	157 KIAS	224 KIAS	120 KIAS	78 KIAS	168 KTAS	1725 fpm	400 fpm @ 100 KIAS
5000' -->									180 KTAS	1250 fpm	125 fpm @ 100 KIAS
Beechcraft (BE58) Baron	74 KIAS	84 KIAS	92 KIAS	105 KIAS	156 KIAS	223 KIAS	115 KIAS	84 KIAS	188 KTAS	1725 fpm	395 fpm @ 101 KIAS
5000' -->									203 KTAS	1325 fpm	150 fpm @ 101 KIAS
Beechcraft (BE76) Duchess	60 KIAS	70 KIAS	71 KIAS	85 KIAS	132 KIAS	194 KIAS	95 KIAS	65 KIAS	148 KTAS	1250 fpm	230 fpm @ 85 KIAS
5000' -->									160 KTAS	900 fpm	90 fpm @ 85 KIAS
Diamond DA42 L360	57 KIAS	64 KIAS	90 KIAS	90 KIAS	126 KIAS	194 KIAS	NA*	65 KIAS	153 KTAS	1119 fpm	185 fpm @ 85 KIAS
5000' -->									160 KTAS	1045 fpm	106 fpm @ 85 KIAS
Diamond DA42 NG	62 KIAS	69 KIAS	85 KIAS	90 KIAS	122 KIAS	188 KIAS	NA*	76 KIAS	147 KTAS	1065 fpm	175 fpm @ 85 KIAS
5000' -->									152 KTAS	996 fpm	122 fpm @ 85 KIAS
Piper PA-34 Seneca	61 KIAS	67 KIAS	76 KIAS	88 KIAS	139 KIAS	204 KIAS	NA*	66 KIAS	157 KTAS	1470 fpm	255 fpm @ 88 KIAS
5000' -->									171 KTAS	1380 fpm	220 fpm @ 88 KIAS
Piper PA-34T Seneca	62 KIAS	64 KIAS	76 KIAS	92 KIAS	136 KIAS	205 KIAS	NA*	66 KIAS	159 KTAS	1500 fpm	290 fpm @ 92 KIAS
5000' -->									169 KTAS	1500 fpm	260 fpm @ 92 KIAS
Piper PA-44 Seminole	55 KIAS	57 KIAS	70 KIAS	88 KIAS	135 KIAS	202 KIAS	NA*	56 KIAS	152 KTAS	1350 fpm	225 fpm @ 88 KIAS
5000' -->									159 KTAS	925 fpm	0 fpm @ 88 KIAS
Piper PA-44T Seminole	56 KIAS	60 KIAS	84 KIAS	88 KIAS	137 KIAS	202 KIAS	NA*	57 KIAS	151 KTAS	1275 fpm	180 fpm @ 88 KIAS
5000' -->									159 KTAS	1175 fpm	150 fpm @ 88 KIAS
Tecnam P2006	53 KIAS	66 KIAS	80 KIAS	80 KIAS	118 KIAS	167 KIAS	NA*	62 KIAS	142 KTAS	1150 fpm	230 fpm @ 80 KIAS
5000' -->									139 KTAS	840 fpm	60 fpm @ 80 KIAS

*Not published by manufacturer

Table 4: Performance (Multi-Engine)

SECTION 6: VISUAL SYSTEM WITH IFR, VFR, DAY, AND NIGHT CAPABILITY

Redbird LD, SD, FMX, MCX Visual System

The visual system is capable of providing a field-of-view of a minimum of 45 degrees horizontally and 30 degrees vertically, simultaneously for each pilot, including adjustable cloud base and visibility in night, dusk and day scenes.

- The Redbird LD, SD, FMX, MCX provides a means of recording the visual response time for the visual system that is installed.
- The Redbird LD, SD, FMX, MCX visual system is free of optical discontinuities and artifacts that create non-realistic cues.
- The visual system is directly displayed on six (6) or (8) LCD monitors inside the cockpit enclosure, situated in an arc around the Pilot. Each monitor is 28 cm tall, and 47 cm wide (36.5 cm x 63.5cm OPTIONAL). Based upon the designated Pilot Eye Point, these monitors provide a horizontal FOV of at least 220 (6 monitors) to 260 (8 monitors) degrees and a vertical FOV of minimally 30 degrees.

Daylight: The visual system provides full color presentations and sufficient surfaces with appropriate textural cues to conduct a visual approach, landing and airport movement. Surface shading effects are consistent with the simulated sun position.

Twilight: The visual system provides full color presentations of reduced ambient intensity, sufficient surfaces with appropriate textural cues that include self-illuminated objects such as road networks, ramp lighting and airport signage, to conduct a visual approach, landing and airport movement. Scenes include a definable horizon and typical terrain characteristics such as fields, roads and bodies of water and surfaces illuminated by representative ownship lighting.

Night: The visual system provides the same as above except the portrayal of reduced ambient intensity; therefore, there is no ground cues that are not self-illuminating or illuminated by ownship lights.

Designated Eye Point: The designated Pilot Eye Point is located 52 cm from the center of the forward most external view monitor, 61 cm from the left most external view monitor and 24 cm from the ceiling of the simulator enclosure. This point is roughly centered over the pilot's seat when it is adjusted to the forward most position, at a height consistent with the height of the pilot's head.

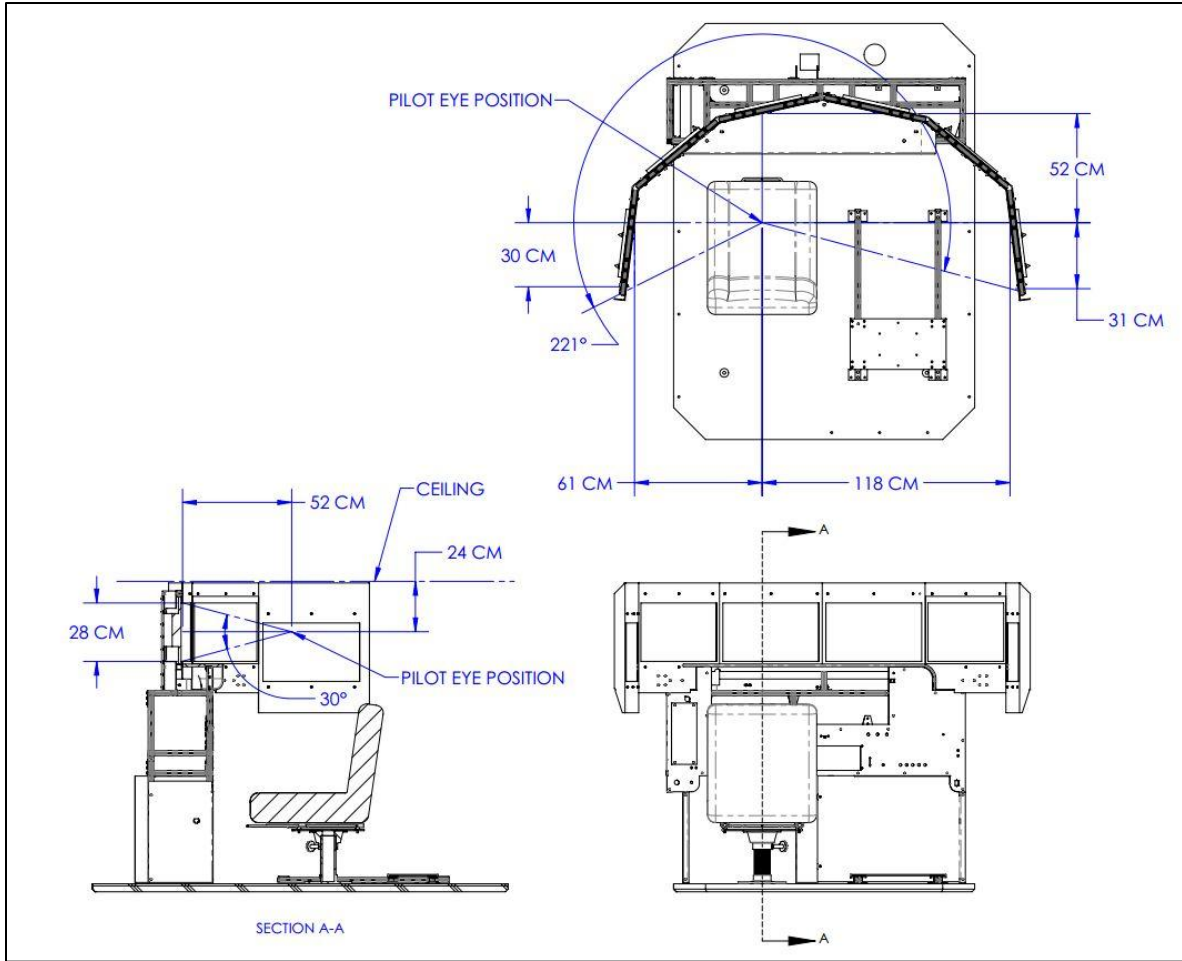

Diagram 1: Designated Eye Point Diagram



Image 65: Visual Displays – Type 1 (22" Display Monitors)

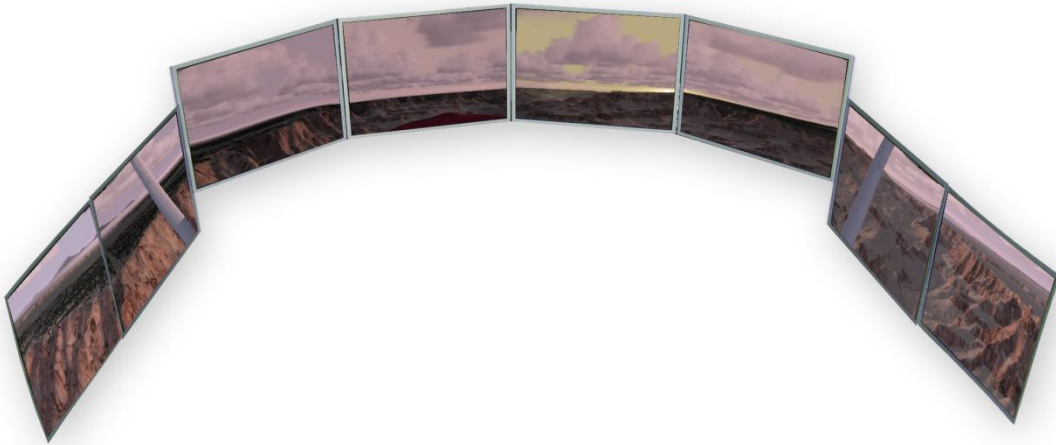

Image 66: Visual Displays – Type 2 (22" Display Monitors)



Image 67: Visual Displays – Type 3 (27” Display Monitors)



Image 68: Visual Displays – Type 4 (27” Display Monitors)

SECTION 7: ATD FUNCTIONS & MANEUVERS CHECKLISTS

AIRPLANE ATD FUNCTION VERIFICATION CHECKLIST

Functions and Maneuvers	Yes, No, or N/A
a. Pre-Takeoff	
(1) Engine start	Yes
(2) Taxi and brake operation	Yes
b. Takeoff	
(1) Run-up and powerplant checks	Yes
(2) Acceleration characteristics	Yes
(3) Nose wheel and rudder steering	Yes
(4) Effect of crosswind	Yes
(5) Instrument	Yes
(6) Flap operation	Yes
(7) Landing gear operation (if retractable)	Yes
c. In-Flight Operations	
(1) Climb	
(i) Normal and max. performance	Yes
(ii) One engine inoperative procedures (Multiengine only)	Yes
(2) Cruise	
(i) Correct performance characteristics (speed vs. power)	Yes
(ii) Normal and steep turns	Yes
(iii) Approach to stalls, (i.e. stall warning), stalls. Execute from takeoff, cruise, and approach and landing configurations.	Yes
(vi) In flight engine shutdown (multi-engine only)	Yes
(v) In flight engine start (multi-engine only)	Yes
(vi) Fuel selector function	Yes
(3) Approach	
(i) Normal (with & without flaps) Check gear horn warning if applicable	Yes
(ii) Single engine approach and landing (multi-engine)	Yes
(iii) Best glide no power	Yes
(iv) Landings	Yes
d. Instrument Approaches	
(1) Nonprecision	
(i) GPS and LPV	Yes
(ii) GPS - WAAS (optional)	Varies by configuration
(iii) All engines operating	Yes
(iv) One engine inoperative (Multi-engine only)	Yes
(v) Approach procedures (VOR, VOR/DME, LOC procedures on an ILS, LDA, RNAV (RNP) or RNAV (GPS) to LNAV, LNAV/VNAV or LPV)	Yes
(2) Precision	
(i) ILS	Yes
(ii) GLS (optional)	No
(iii) Effects of Crosswind	Yes
(iv) One Engine Inoperative (Multi-engine only)	Yes
(v) Missed Approach	Yes
(A) Normal	Yes

(B) With One Engine inoperative (Multi-engine only)	Yes
e. Surface Operations (Post Landing)	
(1) Approach and landing roll	Yes
(2) Braking operation	Yes
(3) Reverse thrust operation, if applicable	Yes
f. Any Flight Phase	
(1) Airplane and Power Plant Systems	
(i) Electrical, mechanical, or hydraulic	Yes
(ii) Flaps	Yes
(iii) Fuel selector and oil temp/pressure	Yes
(vi) Landing gear (if applicable)	Yes
(2) Flight Management and Guidance Systems	
(i) Two axis auto pilot (if standard equipment)	Yes
(ii) Flight director (AATD only) and system displays (if installed)	Yes
(iii) Navigation systems and optional display configurations	Yes
(iv) Stall warning systems avoidance	Yes
(v) Multi-function displays (PFD/MFD) if applicable	Yes
(3) Airborne Procedures	
(i) Holding	Yes
(ii) Uncoordinated turns – slipping and skidding demo	Yes
(iii) Configuration and power changes and resulting pitch changes	Yes
(iv) Compass turns and appropriate errors (if installed)	Yes
(4) Simulated Turbulence in Flight (light, moderate, severe)	Yes
(4) Parking and Engine Shutdown	
(i) Systems operation	Yes
(ii) Parking brake operation (if installed)	Yes
g. Can simulate engine failure, including failures due to simulated loss of oil pressure or fuel starvation.	Yes (Separate Functions)
h. Can simulate the following equipment or system failures:	
(1) Alternator or generator failure.	Yes
(2) Vacuum pump/pressure failure and associated flight instrument failures.	Yes
(3) Gyroscopic flight instrument failures.	Yes
(4) Pitot/static system malfunction and associated flight instrument failures.	Yes
(5) Electronic flight deck display malfunctions.	Yes
(6) Landing gear (if retractable) or flap malfunctions	Yes
i. Independent Instructor Station Requirements (AATD only)	
(1) Displays published airways and holding patterns.	Yes
(2) Displays airplane position and track.	Yes
(3) Displays airplane altitude and speed.	Yes
(4) Displays NAVAIDs and airports.	Yes
(5) Can record and replay airplane ground track history for entire training session.	Yes
(6) Can invoke instrument or equipment failures.	Yes

During the initial start of the trainer, the computer component “self-check” program verifies that all the features of the trainer are in working order. It is not possible to continue the training session unless the problem is resolved, and all the components are functioning properly.

During the initial start-up the ATD has the following **Screen Statement** is displayed on the instructor station or visual display before the trainer is used for training.

“All the flight instruments required for visual and instrument flight rules listed in part 91.205 must be functional at the start of the simulated flight session. Temporary instrument or equipment failures are permitted when practicing emergency procedures. If this simulated flight session will be used for instrument experience or currency requirements, the visual component must be configured to Instrument Meteorological Conditions [IMC] during the simulated flight session, including execution of instrument approaches from the final approach fix until reaching Decision Height [DH], Decision Altitude [DA], or Minimum Decent Altitude [MDA] as appropriate.”

Notice: Any changes or modifications to this training device that have not been reviewed, evaluated, and approved in writing by General Aviation and Commercial Division will terminate FAA approval.